

Penn Engineering

C O M P O N E N T S

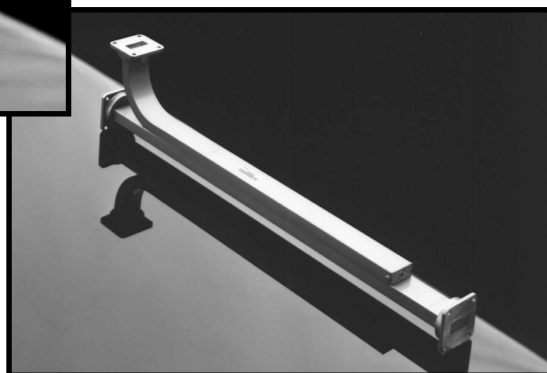
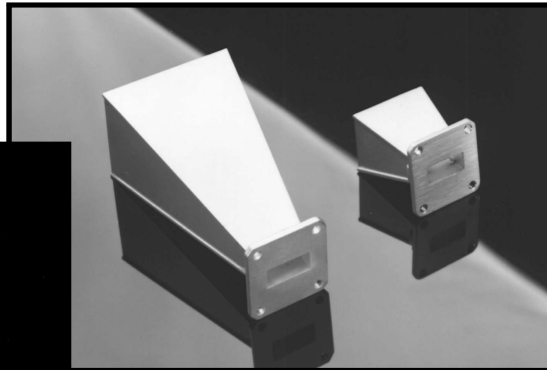
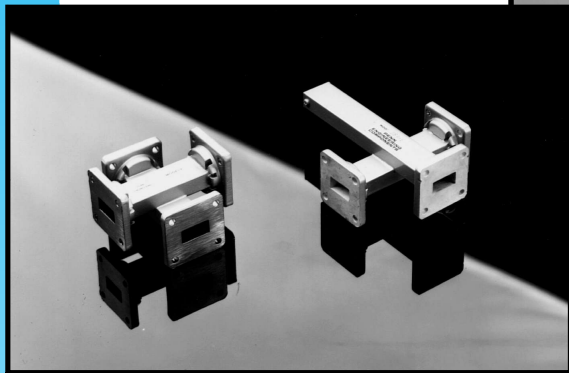

PENN
ENGINEERING
COMPONENTS

29045 Avenue Penn
Valencia, California
91355-5426

(661) 295-2080

FAX (661) 295-2084

www.pennengineering.com

Quality Waveguide Components

~Since 1971~

PENN ENGINEERING COMPONENTS

29045 Avenue Penn
Valencia, California
91355-5426

(661) 295-2080

FAX (661) 295-2084

www.pennengineering.com

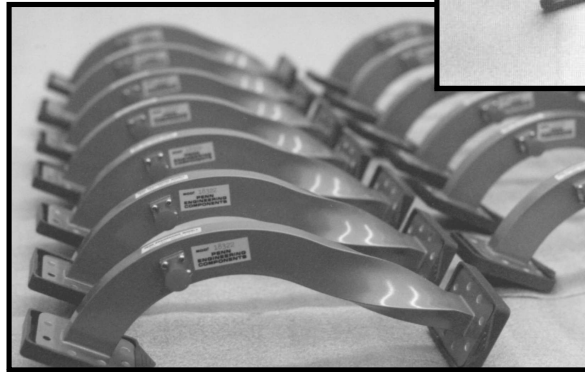
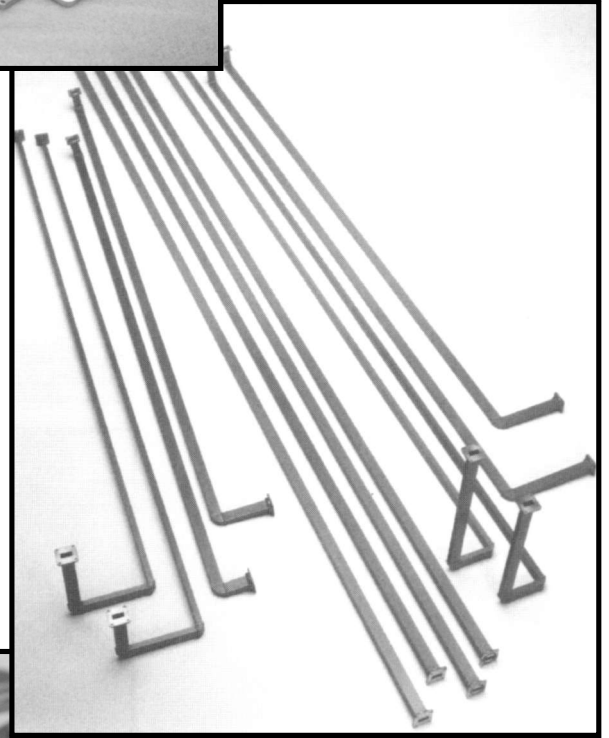
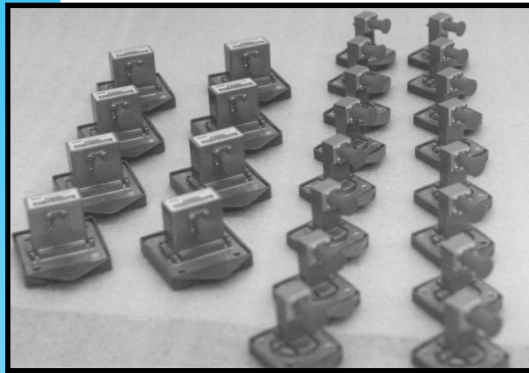
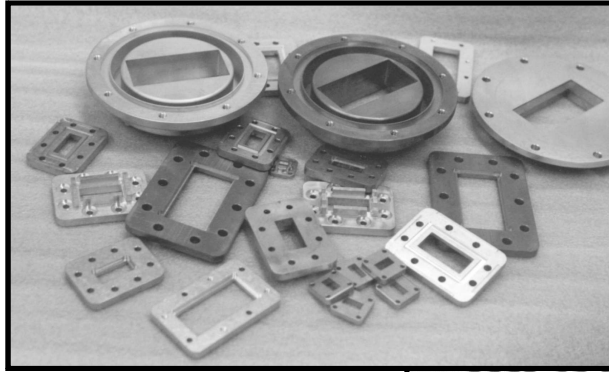











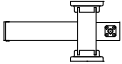
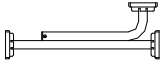
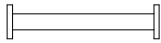
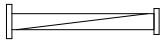
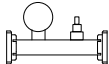

Established in California in 1971, Penn Engineering has many years of Experience and Knowledge in Designing and Manufacturing Waveguide Components for the Laboratory, Radar, Communications, Government, Military, Medical, Aerospace, Space Flight, and various other industries. We are committed to continuous improvement in our Manufacturing, Design, and Test Capabilities.

In addition to our Standard Waveguide Components, we will design and build one of a kind or Production Quantities of Custom Components to your specifications. On request, we also target, design, install, and test Full Waveguide Systems. With our CAD/CAM, CNC, and CMM capabilities, we have the capacity to do prototypes as well as production runs of Waveguide Components, Machined Parts, Flanges, and Castings.

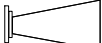
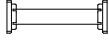
Penn Engineering is an **ISO 9001:2015 Certified** and **AS9100:2016 Compliant** Company. We maintain traceability of all materials that we sell and that we use in our components. Our commitment to Quality is extended to our goal of continuous improvement of our Products and to our Customer Service.

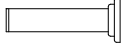
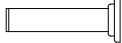
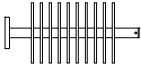
TABLE OF CONTENTS

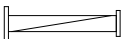
	Adapters - Waveguide to Coax N connector.....	4
	Adapters - Waveguide to Coax SMA, SSMA, and mm connectors.....	6
	Attenuators - Variable.....	8
	Attenuators - Fixed.....	10
	Bends - Formed E & H Plane.....	12
	Bends - Mitre E & H Plane.....	14
	Bulkhead Feed-Through.....	16
	Directional Couplers - Cross-Guide	18
	Directional Couplers - Multihole.....	20
	Flexible Seamless Waveguide Sections.....	22
	Flexible-Twistable Waveguide Sections.....	24
	Pressurizing Sections.....	26
	RF Gaskets.....	28
	Shorting Plates.....	30
	Standard Gain Horns.....	32
	Straight Sections.....	34
	Tees- Waveguide.....	36
	Terminations - Fixed, Low Power.....	38
	Terminations - Fixed, Medium Power.....	40
	Terminations - Fixed, High Power.....	42
	Transitions - Tapered.....	44
	Twists.....	46

**PENN
ENGINEERING
COMPONENTS**

29045 Avenue Penn
Valencia, California
91355-5426

(661) 295-2080

FAX (661) 295-2084

www.pennengineering.com

ADAPTERS- WAVEGUIDE TO TYPE "N"



PENN ENGINEERING offers a line of Type "N" Coax to Waveguide Adapters covering the frequency range of 1.12 to 18.0 GHz. These units are widely used in the test lab and in many commercial applications. Typical Insertion Loss is .1 dB and power handling is typically 150 watts.

As Standard, Aluminum Adapters are Chem-Filmed per MIL-DTL-5541, and all are finished with PENN ENGINEERING'S Polyurethane Blue/Gray Paint.

Low VSWR (1.10:1) Adapters, covering portions of the waveguide band are also available as well as pressure-sealed adapters and High-Power adapters. We will design and build Custom Waveguide to Coax Adapters to your specifications.

PENN ENGINEERING COMPONENTS

29045 Avenue Penn
Valencia, California
91355-5426

(661) 295-2080

FAX (661) 295-2084

www.pennengineering.com

ORDERING INFORMATION - TO ORDER, USE THE FOLLOWING EXAMPLE:

MODEL 1242-1B-NB..... Is a WR-90 to Type "N" female with cover flange
in bronze/brass material, no plating, standard paint

PAINT
 PLATING
 ALLOY
 FLANGE
 WAVEGUIDE SIZE CODE
 COMPONENT TYPE

ALLOY: A= ALUMINUM B=BRONZE/BRASS

FLANGE: 1=COVER 2=CHOKE 3=CMR 4=CPRG 5=CPRF

(See last page for complete list of flanges, materials, and finishes)

WAVEGUIDE TO TYPE "N" CONNECTOR

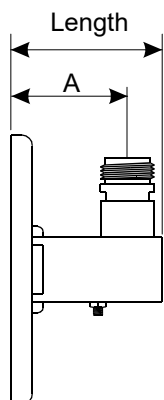
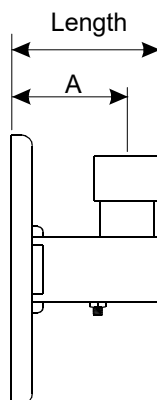
1200 SERIES FEMALE

1300 SERIES MALE

Model #		Waveguide Size EIA	Frequency Range(GHz)	VSWR (Max.)	Length (inches)
Female	Male				
1264	1364	WR-650	1.12-1.70	1.25	5.62
1260	1360	WR-430	1.70-2.60	1.25	4.12
1258	1358	WR-340	2.20-3.30	1.25	3.50
1256	1356	WR-284	2.60-3.95	1.25	3.00
1254	1354	WR-229	3.30-4.90	1.25	2.12
1252	1352	WR-187	3.95-5.85	1.25	2.00
1250	1350	WR-159	4.90-7.05	1.25	2.00
1248	1348	WR-137	5.85-8.20	1.25	1.75
1246	1346	WR-112	7.05-10.0	1.25	1.50
1244	1344	WR-102	7.00-11.0	1.25	1.50
1242	1342	WR-90	8.2-12.4	1.25	1.50
1240	1340	WR-75	10.0-15.0	1.25	1.50
1238	1338	WR-62	12.4-18.0	1.25	1.00

ADAPTERS-WAVEGUIDE TO COAX

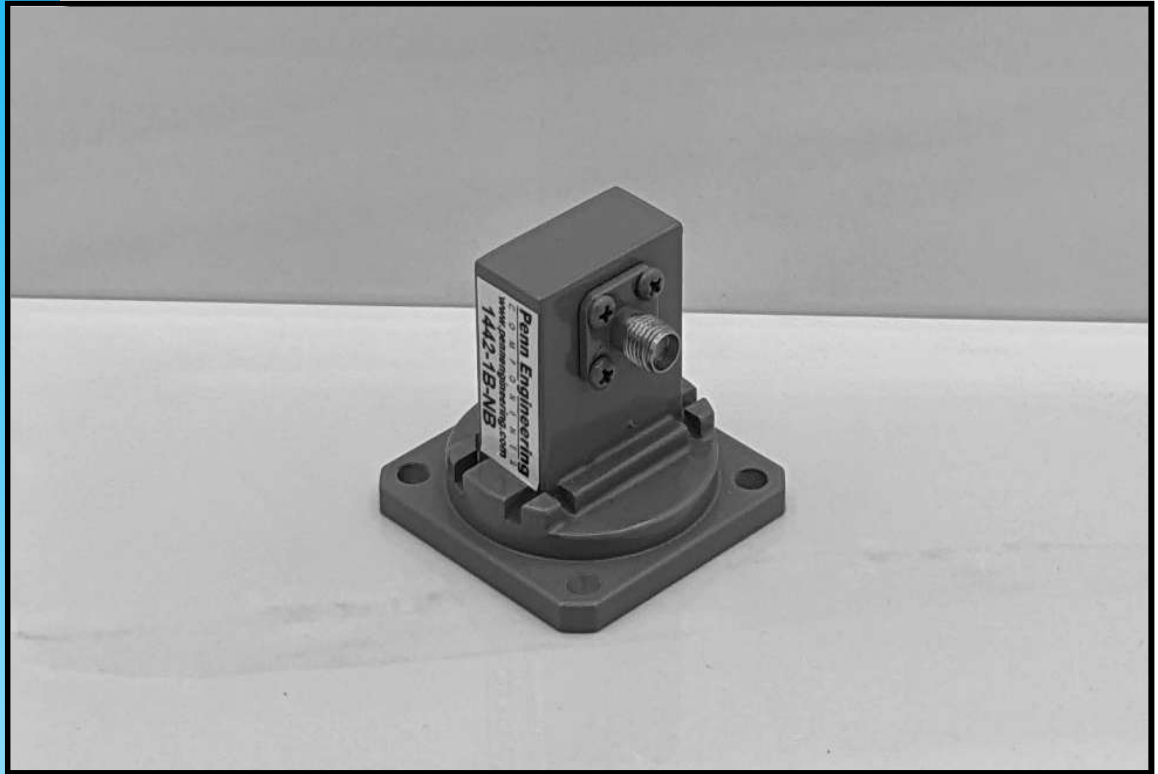
SMA, SSMA, 3.5mm, 2.92mm(K), 2.4mm, and 1.85mm(V) Connectors



PENN ENGINEERING offers a complete line of Coax to Waveguide Adapters with, SMA, SSMA, 3.5mm, 2.92mm("K"), 2.4mm, and 1.85mm("V") connectors covering the frequency range of 1 to 75 Ghz.

These units are widely used in the test lab and in many commercial applications. Typical Insertion Loss is .1 dB and typical Power Handling is 50 watts.

As Standard, Aluminum Adapters are Chem-Filmed per MIL-DTL-5541, and all are finished with PENN ENGINEERING'S Polyurethane Blue/Gray Paint.

Low VSWR (e.g., 1.10:1) Adapters, covering portions of the waveguide band are also available as well as pressure-sealed adapters. We can also design and build Custom Adapters to your specifications.

PENN ENGINEERING COMPONENTS

29045 Avenue Penn
Valencia, California
91355-5426

(661) 295-2080

FAX (661) 295-2084

www.pennengineering.com

ORDERING INFORMATION - TO ORDER, USE THE FOLLOWING EXAMPLE:

MODEL 1442-1B-NB..... Is a WR-90 Type "SMA" with a cover flange in brass/bronze with no plating and standard paint.

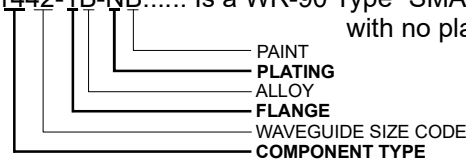

ALLOY: A= ALUMINUM B=BRASS/BRONZE C=COPPER S=SILVER SS=STAINLESS STEEL
FLANGE: 1=COVER 2=CHOKE 3=CMR 4=CPRG 5=CPRF

(See last page for complete list of flanges, materials, and finishes)

WAVEGUIDE TO TYPE SMA, SSMA, 3.5, 2.92(K), 2.4mm, and 1.85mm(V)

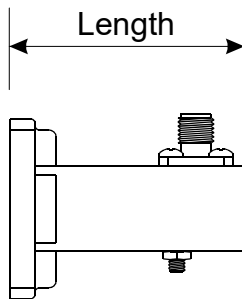
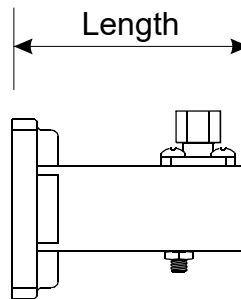
1400 SERIES FEMALE

1500 SERIES MALE

Model #		Connector Type	Waveguide Size EIA	Frequency Range(GHz)	VSWR (max.)	Length (inches)
Female	Male					
1460	1560	SMA	WR-430	1.70-2.60	1.25	4.12
1458	1558	SMA	WR-340	2.20-3.30	1.25	3.50
1456	1556	SMA	WR-284	2.60-3.95	1.25	3.00
1454	1554	SMA	WR-229	3.30-4.90	1.25	2.12
1452	1552	SMA	WR-187	3.95-5.85	1.25	2.00
1450	1550	SMA	WR-159	4.90-7.05	1.25	2.00
1448	1548	SMA	WR-137	5.85-8.20	1.25	1.75
1446	1546	SMA	WR-112	7.05-10.0	1.25	1.50
1444	1544	SMA	WR-102	7.00-11.0	1.25	1.30
1442	1542	SMA	WR-90	8.2-12.4	1.25	1.50
1440	1540	SMA	WR-75	10.0-15.0	1.25	1.50
1438	1538	SMA	WR-62	12.4-18.0	1.25	1.00
1436	1536	SMA	WR-51	15.0-22.0	1.25	1.00
1434	1534	SMA	WR-42	18.0-26.5	1.25	1.00
1432	1532	2.92mm	WR-34	22.0-33.0	1.25	1.00
1430*	1530	2.92 or 2.4mm	WR-28	26.5-40.0	1.30	1.00
1428*	1528	2.92 or 2.4mm	WR-22	33.0-50.0	1.30	1.00
1426*	1526	2.4mm	WR-19	40.0-60.0	1.50	1.00
1424*	1524	1.85mm	WR-15	50.0-67.0	1.50	1.00

*Contact Penn for Full Part Number

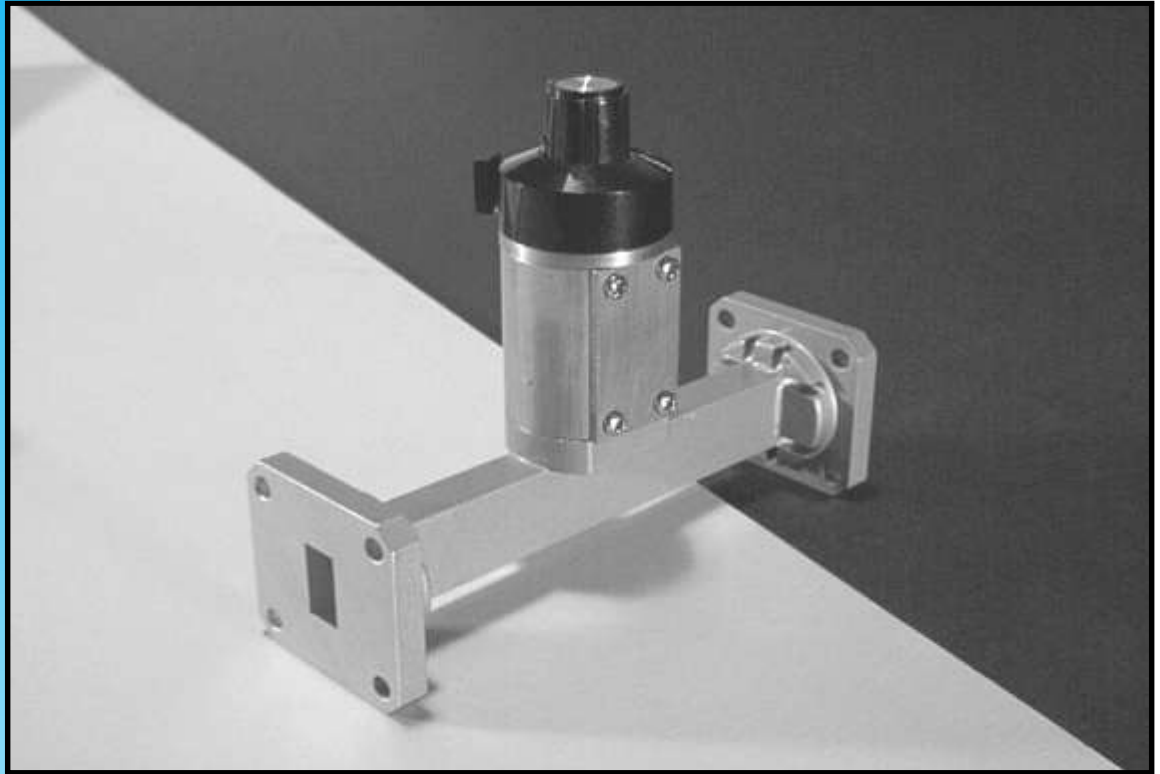
ATTENUATORS-VARIABLE



PENN ENGINEERING offers a line of Variable Waveguide Attenuators for manually adjusting the power level in a waveguide system. These units are typically used when a repeatable attenuation level is desired for calibration and other purposes.

Attenuation range is 0 dB to 40 dB (WR 42, WR 34, and WR 28 are 0 dB to 25 dB). VSWR is 1.20:1 max. Insertion loss is 0.5 dB max. Variable Attenuators can be supplied with a calibration sheet upon request. Calibration is mid-band unless otherwise specified by the customer.

As standard, Aluminum Variable Attenuators are Chem-Filmed per MIL-DTL-5541, and all are finished with PENN ENGINEERING'S Polyurethane Blue/Gray Paint.

PENN ENGINEERING COMPONENTS

29045 Avenue Penn
Valencia, California
91355-5426

(661) 295-2080

FAX (661) 295-2084

www.pennengineering.com

ORDERING INFORMATION - TO ORDER, USE THE FOLLOWING EXAMPLE:

MODEL 3742-11B-NB..... Is a WR-90 Variable Attenuator with cover flanges in brass/bronze with no plating and standard paint.

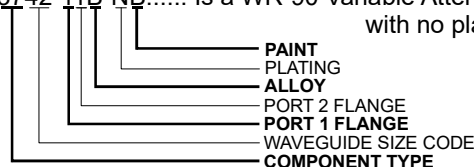

ALLOY: A=ALUMINUM B=BRASS C=COPPER S=SILVER SS=STAINLESS STEEL
FLANGE: 1=COVER 2=CHOKE 3=CMR 4=CPRG 5=CPRF

(See last page for complete list of flanges, materials, and finishes)

29045 Avenue Penn
 Valencia, California
 91355-5426

(661) 295-2080

FAX (661) 295-2084

www.pennengineering.com

VARIABLE ATTENUATORS

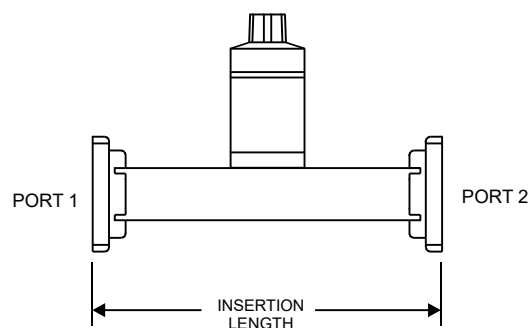

Model #	Waveguide EIA	Calibration Freq. (GHz)	Insertion Length
3756	WR-284	3.20	16.00
3754	WR-229	4.10	13.00
3752	WR-187	4.90	11.00
3750	WR-159	6.00	10.50
3748	WR-137	7.00	8.00
3746	WR-112	8.50	6.50
3744	WR-102	9.00	6.00
3742	WR-90	10.30	5.50
3740	WR-75	12.50	5.00
3738	WR-62	15.20	4.50
3736	WR-51	18.50	4.00
3734	WR-42	22.20	4.00
3732	WR-34	27.50	4.00
3730	WR-28	33.20	4.00

ATTENUATORS-FIXED

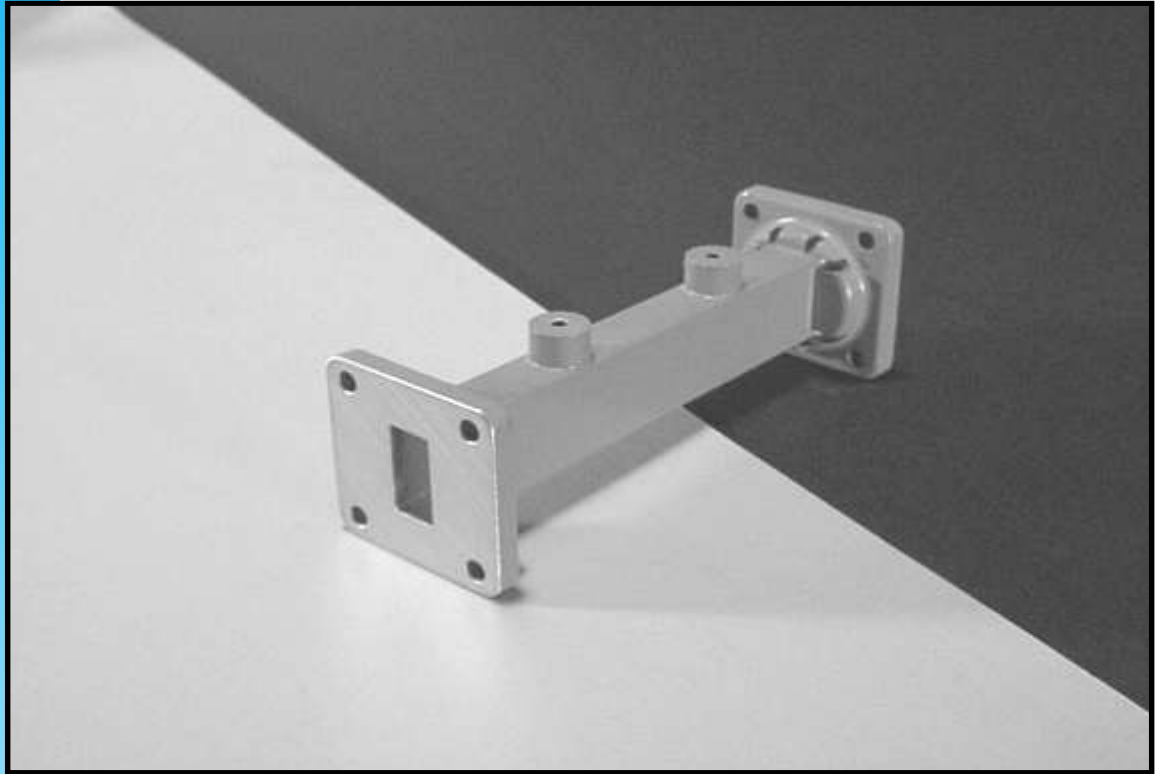

PENN ENGINEERING'S Fixed Pad Attenuators are useful for reducing the amount of power in a line, reflections of loads, or isolating units in a waveguide system. Attenuators can be supplied with any attenuation from 3 dB to 40 dB (WR 42, WR 34, and WR 28 are 3dB to 30 dB). Standard units are 3, 6, 10, 20, 30, and 40 dB. Typical VSWR is 1.20:1

Calibration frequency is set at mid band unless otherwise specified by customer.

As Standard, Aluminum Attenuators are Chem-Filmed per MIL-DTL-5541, and all are finished with PENN ENGINEERING'S Polyurethane Blue/Gray Paint.

We will build Custom Fixed Attenuators to your specifications.

PENN ENGINEERING COMPONENTS

29045 Avenue Penn
Valencia, California
91355-5426

(661) 295-2080

FAX (661) 295-2084

www.pennengineering.com

ORDERING INFORMATION - TO ORDER, USE THE FOLLOWING EXAMPLE:

MODEL 3642-11B20-NB..Is a WR-90 20 dB Fixed Attenuator with cover flanges in brass/bronze with no plating and standard paint

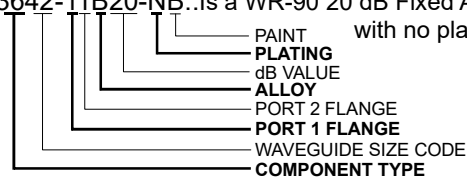

ALLOY: A=ALUMINUM B=BRASS/BRONZE C=COPPER S=SILVER SS=STAINLESS STEEL
FLANGE: 1=COVER 2=CHOKE 3=CMR 4=CPRG 5=CPRF

(See last page for complete list of flanges, materials, and finishes)

FIXED ATTENUATORS

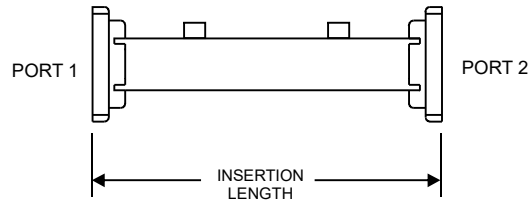

Model #	Waveguide EIA	Calibration Freq. (GHz)	Insertion Length
3656	WR-284	3.20	16.00
3654	WR-229	4.10	13.00
3652	WR-187	4.90	11.00
3650	WR-159	6.00	10.50
3648	WR-137	7.00	9.00
3646	WR-112	8.50	7.00
3644	WR-102	9.00	7.00
3642	WR-90	10.30	6.00
3640	WR-75	12.50	5.00
3638	WR-62	15.20	4.00
3636	WR-51	18.50	4.00
3634	WR-42	22.20	3.00
3632	WR-34	27.50	3.00
3630	WR-28	33.20	2.50

Typical frequency sensitivity:

ATTENUATION	VARIATION OVER BAND	
	WR 284 to WR 51	WR 42, WR 34, and WR 28
3 dB	+/- 0.5 dB	+/- 1.0 dB
6 dB	+/- 1.0 dB	+/- 2.0 dB
10 dB	+/- 1.5 dB	+/- 2.5 dB
20 dB	+/- 2.0 dB	+/- 3.0 dB
30 dB	+/- 2.5 dB	+/- 4.0 dB
40 dB	+/- 3.0 dB	-

BENDS E AND H PLANE

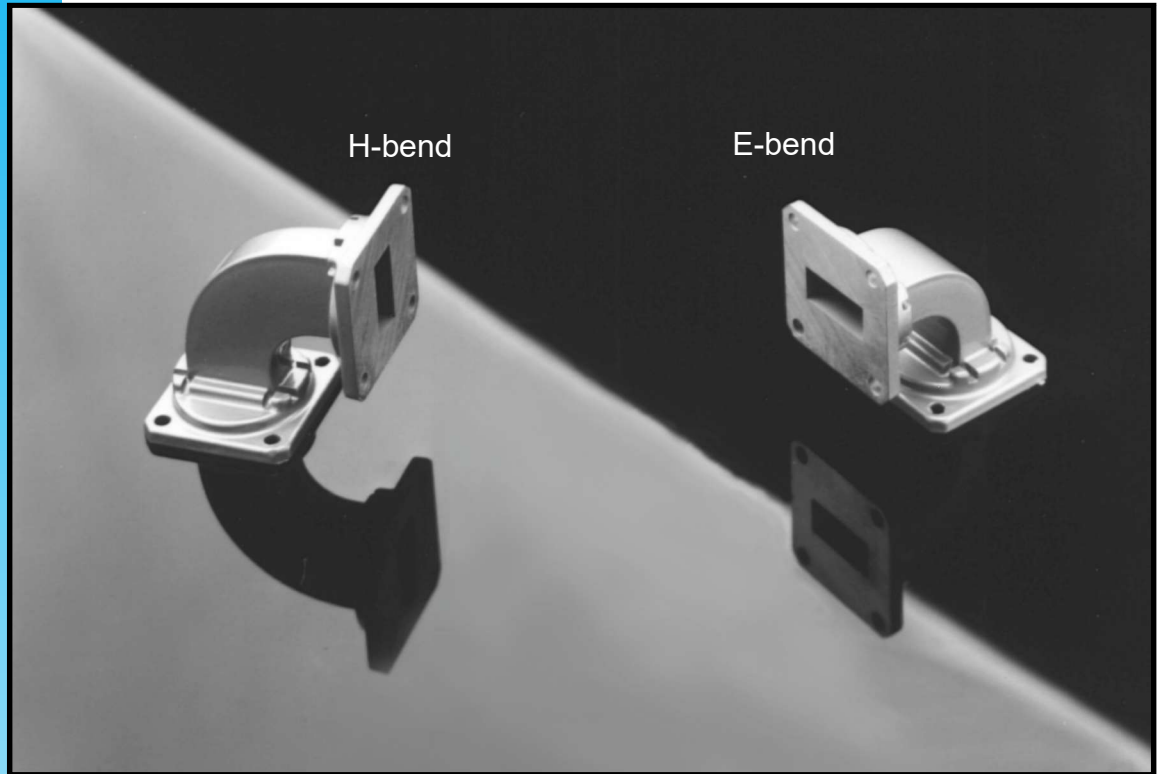

PENN ENGINEERING offers a series of standard 45 and 90 degree E plane and H plane formed bends for use in a waveguide system. Typical VSWR is 1.05:1 over the full frequency range.

As Standard, Aluminum Bends are Chem-Filmed per MIL-DTL-5541, and all are finished with PENN ENGINEERING'S Polyurethane Blue/Gray Paint.

Custom bends offering various angles and configurations are also available upon request.

PENN ENGINEERING COMPONENTS

29045 Avenue Penn
Valencia, California
91355-5426

(661) 295-2080

FAX (661) 295-2084

www.pennengineering.com

ORDERING INFORMATION - TO ORDER, USE THE FOLLOWING EXAMPLE:

MODEL 2042-12B-NB.....Is a WR-90 "E" plane bend with cover/choke flanges in brass/bronze with no plating and standard paint

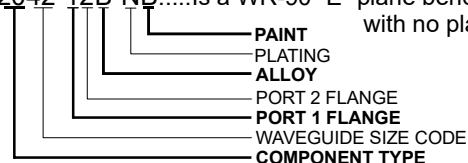

ALLOY: A= ALUMINUM B=BRASS/BRONZE C=COPPER S=SILVER SS=STAINLESS STEEL
FLANGE: 1=COVER 2=CHOKE 3=CMR 4=CPRG 5=CPRF

(See last page for complete list of flanges, materials, and finishes)

RADIUS BEND 90°

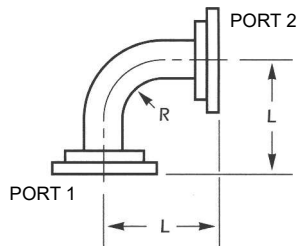

Model #	90 Deg. E-Bend		Model #	90 Deg. H-Bend		Waveguide EIA	Frequency Range(GHz)
	L	R		L	R		
2058	12.0	7.0	2158	12.0	5.0	WR-340	2.20-3.30
2056	7.75	6.0	2156	7.25	4.0	WR-284	2.60-3.95
2054	3.625	2.0	2154	4.25	2.0	WR-229	3.30-4.90
2052	5.062	2.0	2152	5.562	2.0	WR-187	3.95-5.85
2050	2.5	1.0	2150	2.875	1.0	WR-159	4.90-7.05
2048	2.375	1.0	2148	2.75	1.0	WR-137	5.85-8.20
2046	2.062	.750	2146	2.375	.750	WR-112	7.05-10.0
2044	2.00	.750	2144	2.00	.5	WR-102	7.00-11.0
2042	1.437	.5	2142	1.687	.5	WR-90	8.20-12.4
2040	1.437	.5	2140	1.687	.5	WR-75	10.0-15.0
2038	1.656	.5	2138	1.812	.5	WR-62	12.4-18.0
2036	1.656	.5	2136	1.812	.5	WR-51	15.0-22.0
2034	1.25	.5	2134	1.375	.5	WR-42	18.0-26.5
2032	1.25	.5	2132	1.375	.5	WR-34	22.0-33.0
2030	1.234	.5	2130	1.312	.5	WR-28	26.5-40.0
2028	1.234	.5	2128	1.312	.5	WR-22	33.0-50.0
2026	1.234	.5	2126	1.312	.5	WR-19	40.0-60.0
2024	1.234	.5	2124	1.312	.5	WR-15	50.0-75.0
2022	1.234	.5	2122	1.312	.5	WR-12	60.0-90.0
2020	1.234	.5	2120	1.312	.5	WR-10	75.0-110.0

RADIUS BEND 45°

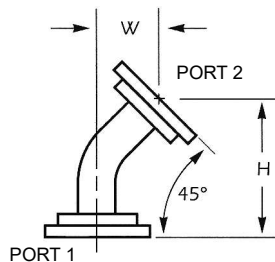

(ALL BEND RADII SAME AS 90 DEG. BENDS)

Model #	45 Deg. E-Bend		Model #	45 Deg. H-Bend		Waveguide EIA	Frequency Range(GHz)
	W	H		W	H		
2256	1.875	4.5	2356	2.093	5.031	WR-284	2.60-3.95
2254	1.062	2.656	2354	1.312	3.062	WR-229	3.30-4.90
2252	1.437	3.468	2352	1.593	3.812	WR-187	3.95-5.85
2250	1.25	3.0	2350	1.218	2.906	WR-159	4.90-7.05
2248	1.125	2.687	2348	1.218	2.937	WR-137	5.85-8.20
2246	1.093	2.625	2346	1.187	2.875	WR-112	7.05-10.0
2244	1.093	2.625	2344	1.187	2.875	WR-102	7.00-11.0
2242	0.968	2.312	2342	1.031	2.5	WR-90	8.20-12.4
2240	0.687	1.687	2340	0.687	1.687	WR-75	10.0-15.0
2238	0.687	1.687	2338	0.687	1.687	WR-62	12.4-18.0
2236	0.687	1.687	2336	0.687	1.687	WR-51	15.0-22.0
2234	0.687	1.687	2334	0.687	1.687	WR-42	18.0-26.5
2232	0.687	1.687	2332	0.687	1.687	WR-34	22.0-33.0
2230	0.687	1.687	2330	0.687	1.687	WR-28	26.5-40.0
2228	0.687	1.687	2328	0.687	1.687	WR-22	33.0-50.0
2226	0.687	1.687	2326	0.687	1.687	WR-19	40.0-60.0
2224	0.687	1.687	2324	0.687	1.687	WR-15	50.0-75.0
2222	0.687	1.687	2322	0.687	1.687	WR-12	60.0-90.0
2220	0.687	1.687	2320	0.687	1.687	WR-10	75.0-110.0

PENN
ENGINEERING
COMPONENTS

29045 Avenue Penn
Valencia, California
91355-5426

(661) 295-2080

FAX (661) 295-2084

www.pennengineering.com

BENDS - MITER E & H PLANE

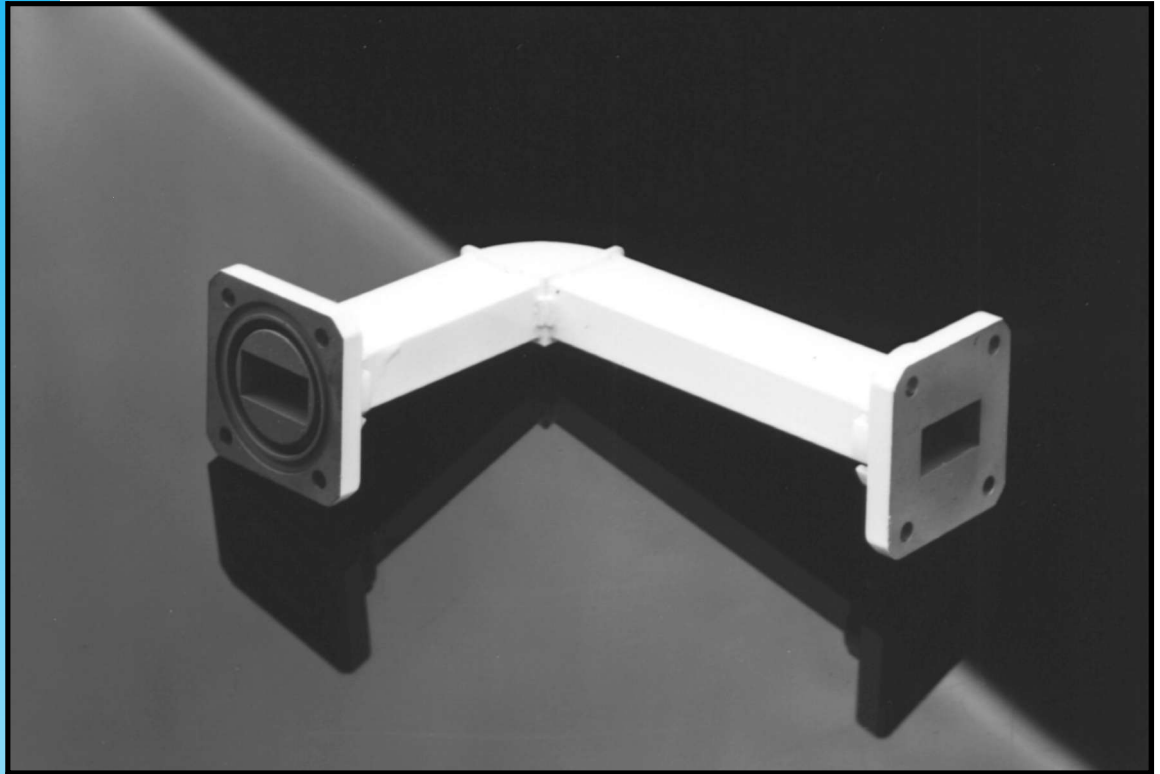

H-plane bend shown

PENN ENGINEERING will build mitre bend assemblies to your dimensions and specifications. Specify "E" or "H" plane bend, leg length, and flange type, and you have a custom bend to fit into your waveguide system.

Typical VSWR for mitred bend assemblies is 1.05:1 over the full frequency range.

As Standard, Aluminum Bends are Chem-Filmed per MIL-DTL-5541, and all are finished with PENN ENGINEERING'S Polyurethane Blue/Gray Paint.

PENN ENGINEERING COMPONENTS

29045 Avenue Penn
Valencia, California
91355-5426

(661) 295-2080

FAX (661) 295-2084

www.pennengineering.com

ORDERING INFORMATION - TO ORDER, USE THE FOLLOWING EXAMPLE:

MODEL 2442-12B12.600-3.956-NB Isa WR-90 Miter E-plane with cover/choke flanges in bronze

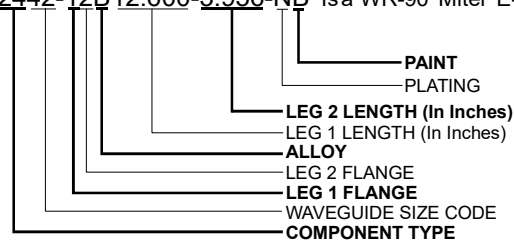

ALLOY: A=ALUMINUM B=BRASS C=COPPER S=SILVER SS=STAINLESS STEEL
FLANGE: 1=COVER 2=CHOKE 3=CMR 4=CPRG 5=CPRF

(See last page for complete list of flanges, materials, and finishes)

MITERED BEND 90°

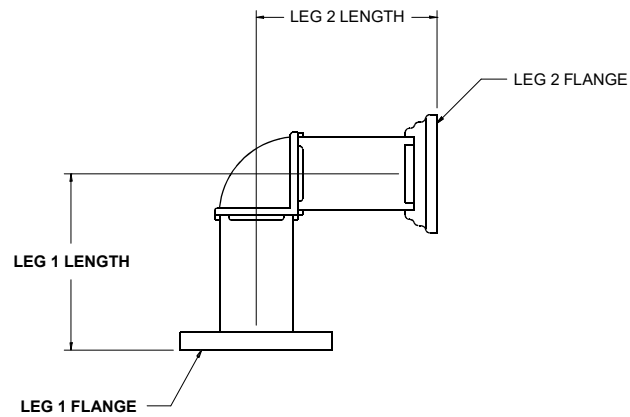

90 Degree "E" Plane Model #	90 Degree "H" plane Model #	Waveguide EIA	Frequency Range (GHz)
2456	2556	WR 284	2.60-3.95
2454	2554	WR 229	3.30-4.90
2452	2552	WR 187	3.95-5.85
2450	2550	WR 159	4.90-7.05
2448	2548	WR 137	5.85-8.20
2446	2546	WR 112	7.05-10.0
2444	2544	WR 102	7.00-11.0
2442	2542	WR 90	8.20-12.4
2440	2540	WR 75	10.0-15.0
2438	2538	WR 62	12.4-18.0
2436	2536	WR 51	15.0-22.0
2434	2534	WR 42	18.0-26.5
2430	2530	WR 28	26.5-40.0

MITERED BEND 45°

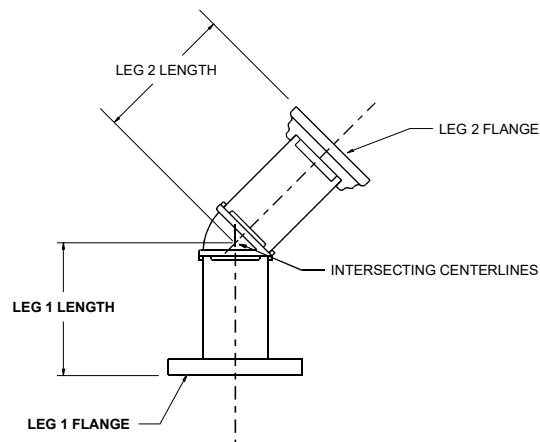

90 Degree "E" Plane Model #	90 Degree "H" plane Model #	Waveguide EIA	Frequency Range (GHz)
2656	2756	WR 284	2.60-3.95
2654	2754	WR 229	3.30-4.90
2652	2752	WR 187	3.95-5.85
2650	2750	WR 159	4.90-7.05
2648	2748	WR 137	5.85-8.20
2646	2746	WR 112	7.05-10.0
2644	2744	WR 102	7.00-11.0
2642	2742	WR 90	8.20-12.4
2640	2740	WR 75	10.0-15.0
2638	2738	WR 62	12.4-18.0
2636	2736	WR 51	15.0-22.0
2634	2734	WR 42	18.0-26.5
2630	2730	WR 28	26.5-40.0

BULKHEAD FEED-THROUGH

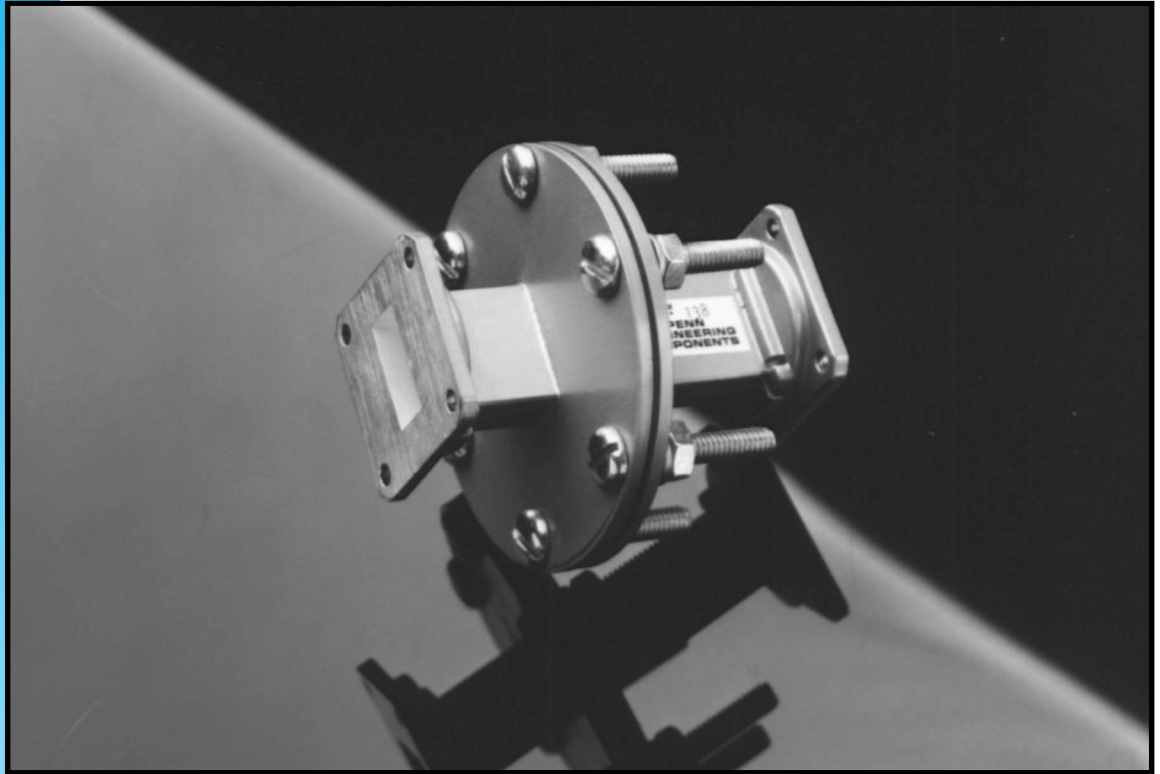

Bulkhead Feed-through units are used when a waveguide system must pass through a pressurized wall or cabinet. A Neoprene gasket, a backing ring, and stainless steel mounting hardware are included with each unit. *(Note: You can use the backing ring as a drilling template!)*

As Standard, Aluminum Bulkheads are Chem-Filmed per MIL-DTL-5541, and all are finished with PENN ENGINEERING'S Polyurethane Blue/Gray Paint.

Custom Bulkhead Flanges can be fabricated to your specifications.

PENN ENGINEERING COMPONENTS

29045 Avenue Penn
Valencia, California
91355-5426

(661) 295-2080

FAX (661) 295-2084

www.pennengineering.com

ORDERING INFORMATION - TO ORDER, USE THE FOLLOWING EXAMPLE:

MODEL 4242-11B-NBIs a WR-90 unit with cover flanges in brass with no plating and standard paint

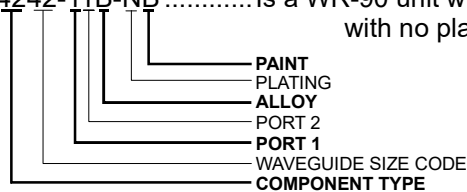

ALLOY: A=ALUMINUM B=BRASS C=COPPER S=SILVER SS=STAINLESS STEEL
FLANGE: 1=COVER 2=CHOKE 3=CMR 4=CPRG 5=CPRF

(See last page for complete list of flanges, materials, and finishes)

BULKHEAD FEED-THROUGH

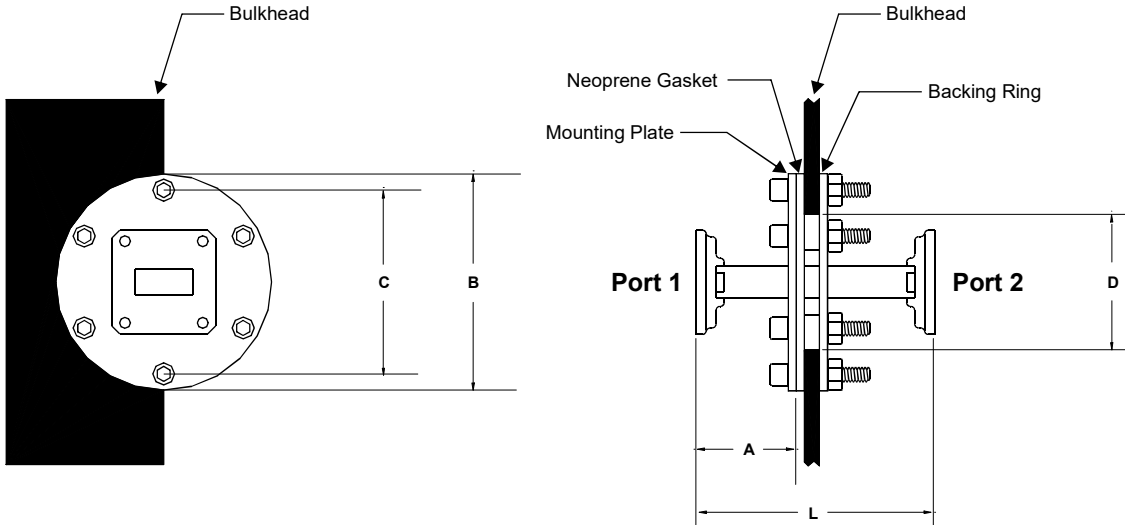

Model #	Waveguide Size EIA	Frequency Range GHz	A	B	C (Bolt Circle)	D (Hole in Bulkhead)	L
4256	WR 284	2.60-3.95	1.625	7.25	6.5*	5.5	4.25
4254	WR 229	3.30-4.90	1.625	6.75	6.00*	5.00	4.25
4252	WR 187	3.95-5.85	1.625	5.25	4.625*	3.75	4.25
4250	WR 159	4.90-7.05	1.625	6.00	5.250*	4.25	4.25
4248	WR 137	5.85-8.20	1.625	4.75	4.00*	3.125	4.25
4246	WR 112	7.05-10.0	1.625	4.00	3.250*	2.625	4.25
4244	WR 102	7.00-11.0	1.625	4.00	3.250*	2.625	4.25
4242	WR 90	8.20-12.4	1.375	3.375	2.875**	2.125	3.75
4240	WR 75	10.0-15.0	1.375	3.375	2.875**	2.125	3.75
4238	WR 62	12.4-18.0	1.00	3.375	2.875**	2.125	3.00
4236	WR 51	15.0-22.0	1.00	3.375	2.875**	2.125	3.00
4234	WR 42	18.0-26.5	1.00	3.375	2.875**	2.125	3.00
4232	WR 34	22.0-33.0	1.00	3.00	2.875**	2.125	3.00
4230	WR 28	26.5-40.0	1.00	3.00	2.500**	1.875	3.00
4228	WR 22	33.0-50.0	1.00	3.00	2.500**	1.875	3.00
4226	WR 19	40.0-60.0	1.00	3.00	2.500**	1.875	3.00
4224	WR 15	50.0-75.0	1.00	3.00	2.500**	1.875	3.00
4222	WR 12	60.0-90.0	1.00	3.00	2.500**	1.875	3.00
4220	WR 10	75.0-110.0	1.00	3.00	2.500**	1.875	3.00

*Diameter of bolt hole circle for 8 holes 1/4" in diameter

**Diameter of bolt hole circle for 6 holes 1/4" in diameter

PENN
ENGINEERING
COMPONENTS

29045 Avenue Penn
Valencia, California
91355-5426

(661) 295-2080

FAX (661) 295-2084

www.pennengineering.com

CROSS GUIDE DIRECTIONAL COUPLERS

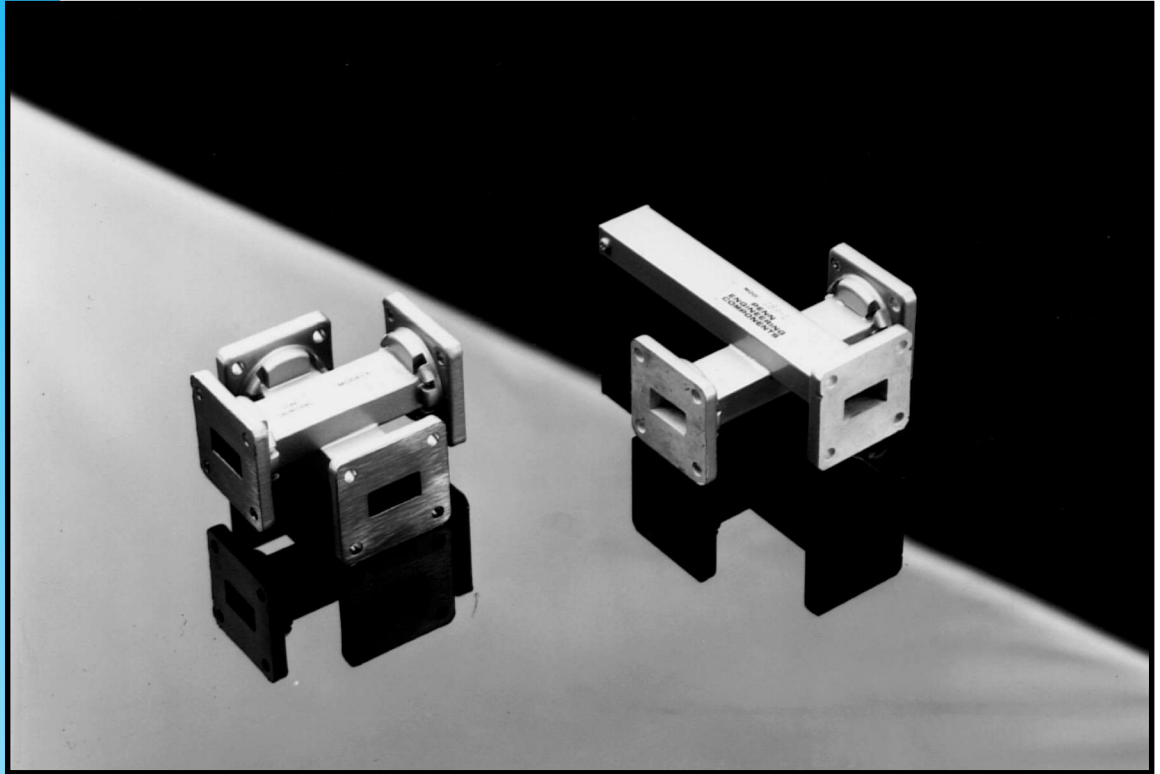

PENN ENGINEERING'S Cross guide Directional Couplers are a cost effective method of sampling the power traveling through a waveguide system. Terminated models sample power in one direction while 4 port models sample power in both directions. Our Couplers are CNC machined for high precision and individually tuned. Fullband directivity is 15 dB min.

Mid-band nominal coupling values of 20, 30, 40, & 50 dB are standard. Other values are available upon request.

As Standard, Aluminum Couplers are Chem-Filmed per MIL-DTL-5541, and all are finished with PENN ENGINEERING'S Polyurethane Blue/Gray Paint.

PENN ENGINEERING COMPONENTS

29045 Avenue Penn
Valencia, California
91355-5426

(661) 295-2080

FAX (661) 295-2084

www.pennengineering.com

ORDERING INFORMATION - TO ORDER, USE THE FOLLOWING EXAMPLE:

MODEL 5442-1111B-20-NB... Is a WR-90 20 dB unterminated model with cover flanges on all ports in brass with no plating and standard paint

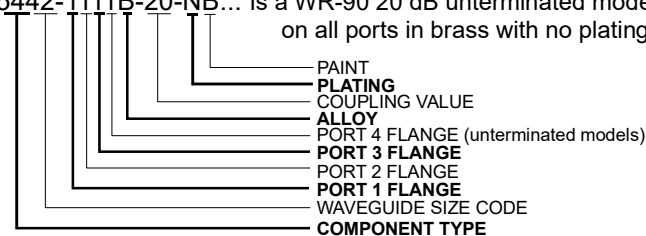

ALLOY: A=ALUMINUM B=BRASS C=COPPER S=SILVER SS=STAINLESS STEEL
FLANGE: 1=COVER 2=CHOKE 3=CMR 4=CPRG 5=CPRF 6=SMA (Female) 7="N" (Female)

(See last page for complete list of flanges, materials, and finishes)

CROSS GUIDE DIRECTIONAL COUPLERS

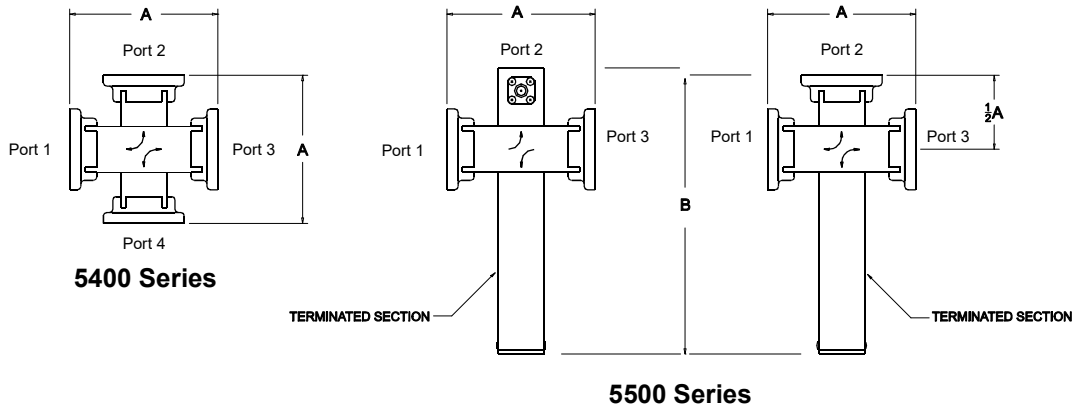

Unterminated Model No.	Terminated Model No.	Waveguide Size EIA	Frequency Range GHz	Dimension "A"	Dimension "B" *
5464	5564	WR-650	1.12-1.70	10.75	size on request
5460	5560	WR-430	1.70-2.60	9	size on request
5456	5556	WR-284	2.60-3.95	7.5	15.50
5454	5554	WR-229	3.30-4.90	6.5	14.12
5452	5552	WR-187	3.95-5.85	5.75	12.50
5450	5550	WR-159	5.90-6.50	5.25	10.56
5448	5548	WR-137	5.85-8.20	5	8.87
5446	5546	WR-112	7.05-10.0	4	8.68
5444	5544	WR-102	7.00-11.0	3.5	8.50
5442	5542	WR-90	8.20-12.4	3	6.50
5440	5540	WR-75	10.0-15.0	2.75	6.00
5438	5538	WR-62	12.4-18.0	2.5	4.87
5436	5536	WR-51	15.0-22.0	2.5	4.31
5434	5534	WR-42	18.0-26.5	2.5	4.25
5432	5532	WR-34	22.0-33.0	2.5	4.25
5430	5530	WR-28	28.5-40.0	1.5	4.25

* Terminated models only

DIRECTIONAL COUPLERS-MULTIHOLE

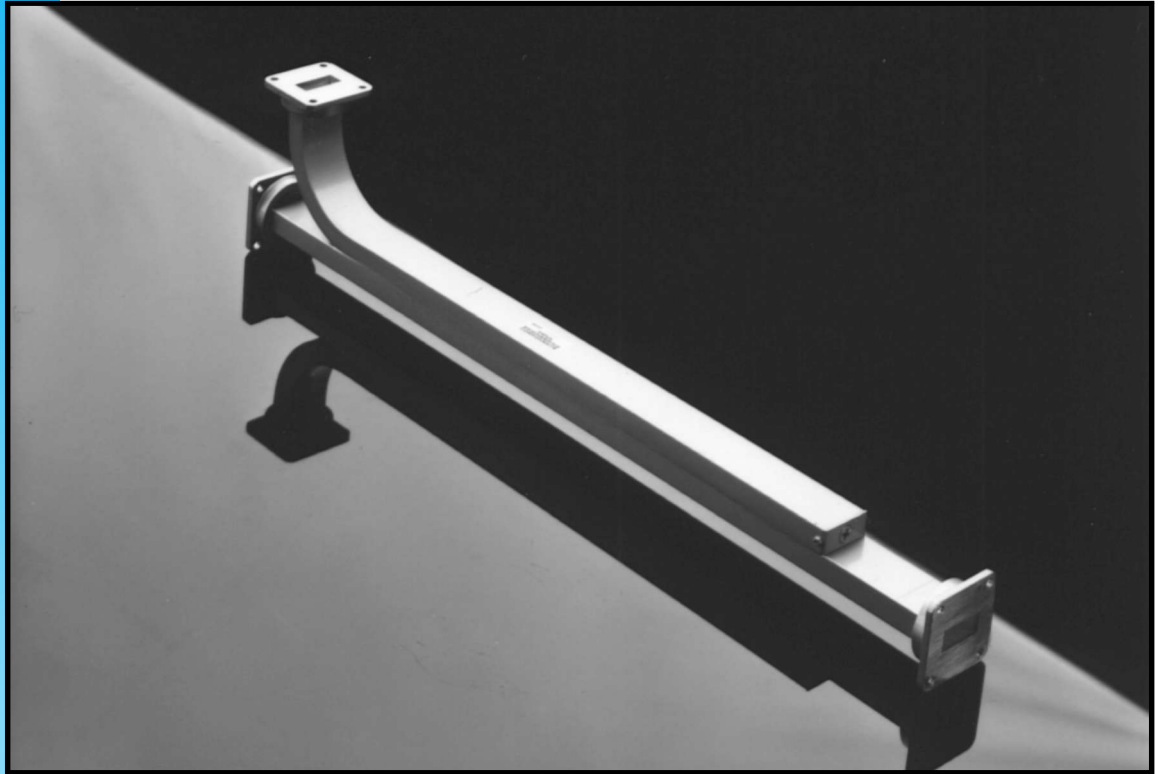

PENN ENGINEERING'S Directional Couplers are an excellent method for measuring the microwave energy traveling through a waveguide system. Coupling values of 3, 6, and 10 dB are available with nominal coupling values of +/- .4dB. Coupling values of 20, 30, and 40 dB are available with nominal coupling value of +/- 1.0 dB (models in WR 28, WR 34, WR 42, and WR 51 coupling values are +/- .6 dB and +/- 1.2 dB)
Custom coupling values are available on request.

Main line VSWR is 1.05:1 maximum (1.10:1 for the 3 dB coupling)

Broad band directivity is greater than 40 dB (except for the WR-28, WR-42, and WR-51 which is 35 dB.) Broad band VSWR through coupled port (with flange) is 1.15-1.2 dB.

As Standard, Aluminum Couplers are Chem-Filmed per MIL-DTL-5541, and all are finished with PENN ENGINEERING'S Polyurethane Blue/Gray Paint.

ORDERING INFORMATION - TO ORDER, USE THE FOLLOWING EXAMPLE:

MODEL 5042-111B-10-NB..... Is a WR-90 10dB coupler in copper alloy with cover flanges on all three ports with no plating and standard paint

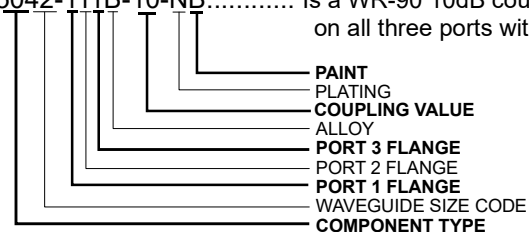

ALLOY: A=ALUMINUM B=BRASS C=COPPER S=SILVER SS=STAINLESS STEEL
FLANGE: 1=COVER 2=CHOKE 3=CMR 4=CPRG 5=CPRF 6=SMA (Female) 7="N" (Female)

(See last page for complete list of flanges, materials, and finishes)

**PENN
ENGINEERING
COMPONENTS**

29045 Avenue Penn
Valencia, California
91355-5426

(661) 295-2080

FAX (661) 295-2084

www.pennengineering.com

DIRECTIONAL COUPLERS-MULTIHOLE

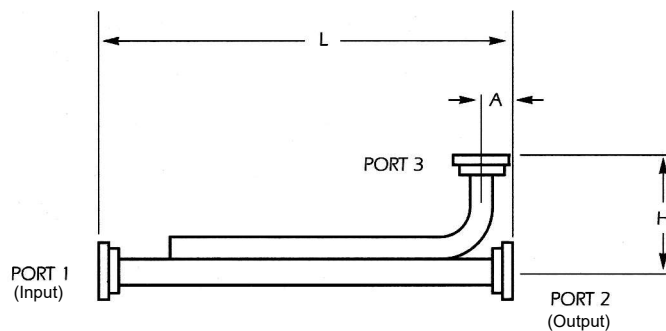

Model No.	Waveguide Size EIA	Frequency Range GHz	L	A	H
5064	WR 650	1.12-1.70	on request	on request	on request
5060	WR 430	1.70-2.60	on request	on request	on request
5058	WR 340	2.20-3.30	on request	on request	on request
5056	WR 284	2.60-3.95	50.25	2.656	9.18
5054	WR 229	3.30-4.90	42.0	1.0	6.81
5052	WR 187	3.95-5.85	34.625	1.812	6.43
5050	WR 159	4.90-7.05	32.5	0.875	5.25
5048	WR 137	5.85-8.20	26.5	1.562	3.06
5046	WR 112	7.05-10.0	18.625	0.937	3.06
5044	WR 102	7.00-11.0	18.0	0.875	2.25
5042	WR 90	8.20-12.4	16.687	0.812	1.93
5040	WR 75	10.00-15.0	15.0	0.75	2.50
5038	WR 62	12.4-18.0	13.75	0.656	2.18
5036	WR 51	15.0-22.0	12.0	0.656	2.12
5034	WR 42	18.0-26.5	9.5	0.437	1.25
5032	WR 34	22.0-33.0	9.0	0.437	1.25
5030	WR 28	26.5-40.0	6.5*	0.375	1.12
5028	WR 22	33.0-50.0	6.0	0.375	1.12

*10dB, 6dB, and 3dB models are 8.62" Length

FLEXIBLE SEAMLESS WAVEGUIDE



PENN ENGINEERING offers a wide variety of Flexible Seamless Waveguide Sections in many different sizes and configurations. These sections flex without impairing VSWR or attenuation. Standard Flex brass tubing with brass flanges and a silicone jacket. Seamless flex will hold pressure with or without jacket.

Aluminum flanges are also available.

We will quote you on custom Flex sections built to your specifications.

PENN ENGINEERING COMPONENTS

29045 Avenue Penn
Valencia, California
91355-5426

(661) 295-2080

FAX (661) 295-2084

www.pennengineering.com

Ordering Information - To order use the following example:

Model 4642-12A12V.....is a WR-90 Seamless Flex section 12" long w/ Vinyl Jacket and aluminum cover/choke flanges

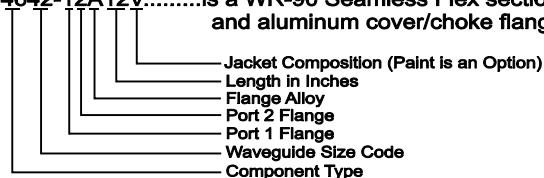

ALLOY: A= ALUMINUM B=BRASS

FLANGE: 1=COVER 2=CHOKE 3=CMR 4=CPRG 5=CPRF

JACKET: N=NEOPRENE P=POLYSULFIDE (BRUSH-ON) S=SILICONE V=VINYL (BRUSH-ON)

(See last page for complete list of flanges, materials, and finishes)

FLEXIBLE SEAMLESS WAVEGUIDE SPECIFICATIONS

MODEL NO.	EIA WR SIZE	FREQ. RANGE GHz	*VSWR	**ATTEN.	Typical Mechanical Specifications				Power Handling	
					Bend Radii to Centerline				CW Power In Watts	Peak Power In Kilowatts
					With Jacket (in Inches) E-Plane	H-Plane	Without Jacket (in Inches) E-Plane	H-Plane		
4628	22	33.0-50.0	1.35	1.000	.75	1.13	.44	.94	75	12
4630	28	26.5-40.0	1.30	0.500	.75	1.13	.44	.94	150	20
4632	34	22.0-33.0	1.30	0.350	.88	1.25	.57	.88	200	30
4634	42	18.0-26.5	1.20	0.320	.88	1.25	.57	.88	300	39
4636	51	15.0-22.0	1.20	0.320	.90	1.40	.63	1.0	500	70
4638	62	12.4-18.0	1.12	0.150	1.00	1.88	.69	1.25	1,000	90
4640	75	10.0-15.0	1.10	0.120	1.13	2.25	.63	1.25	1,500	140
4642	90	8.20-12.4	1.10	0.100	1.75	2.50	1.25	1.50	3,000	180
4644	102	7.00-11.0	1.10	0.060	2.00	2.88	1.30	1.94	4,000	300
4646	112	7.05-10.0	1.10	0.060	2.25	3.25	1.40	1.82	4,000	315
4648	137	5.85-8.20	1.10	0.050	2.38	3.38	1.50	2.07	5,000	500
4650	159	4.90-7.05	1.10	0.040	4.00	6.00	1.60	2.25	6,000	1,100
4652	187	3.95-5.85	1.08	0.030	4.38	6.50	1.94	3.00	6,500	1,250
4654	229	3.30-4.90	1.07	0.020	6.50	8.00	2.13	3.25	8,000	1,550
4656	284	2.60-3.95	1.07	0.018	7.00	9.50	2.94	5.50	10,000	2,000
4658	340	2.20-3.30	1.07	0.010	10.0	16.0	4.25	6.00	16,000	3,700
4660	430	1.70-2.60	1.07	0.010	12.0	25.0	4.82	6.63	20,000	4,700
4664	650	1.12-1.70	1.06	0.010	20.0	40.0	14.0	28.0	20,000	10,700

*VSWR is per 2 Ft. Section

**Attenuation (Insertion Loss) is dB per Ft.

FLEXIBLE TWISTABLE WAVEGUIDE

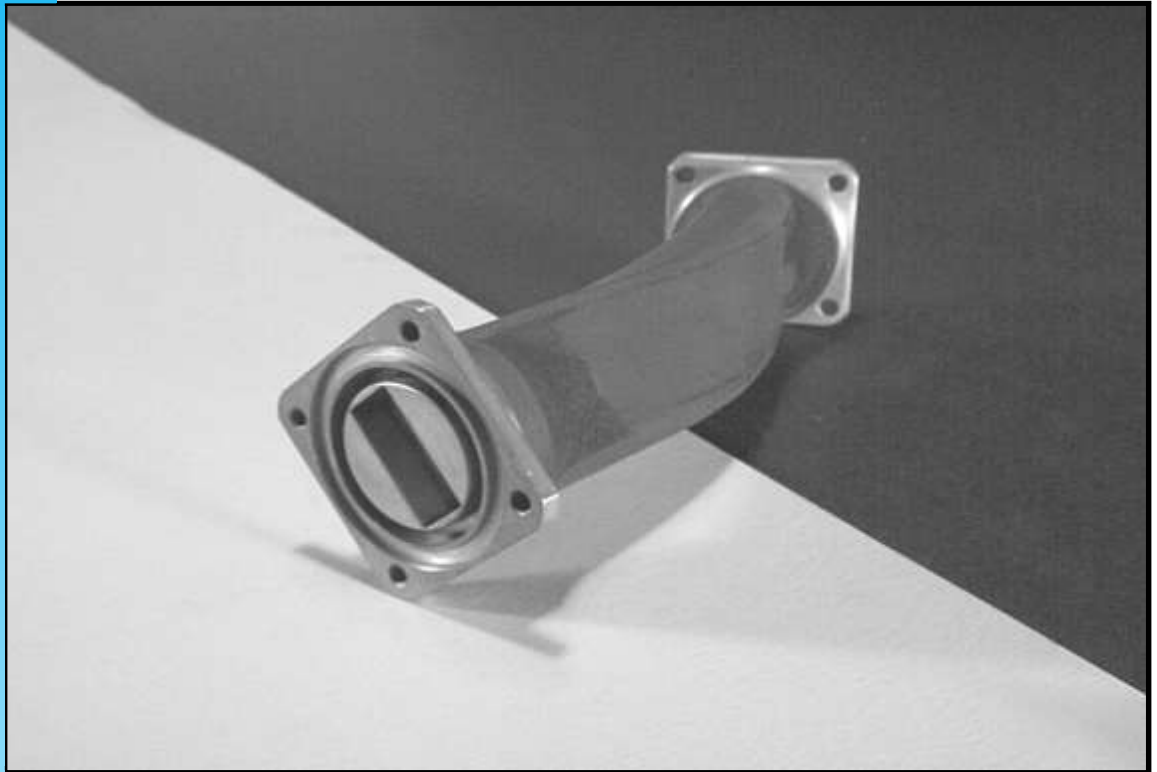

PENN ENGINEERING offers a wide variety of Twistable Flexible waveguide in many different sizes and configurations. These sections flex on the E and H planes as well as twist without impairing VSWR or attenuation. Standard Flex sections are silver plated brass with brass flanges and are available with or without neoprene/vinyl jacket. Note: Twistable flex sections will not hold pressure without a jacket.

Aluminum flanges are also available.

We will quote you on custom Flex sections built to your specifications.

PENN ENGINEERING COMPONENTS

29045 Avenue Penn
Valencia, California
91355-5426

(661) 295-2080

FAX (661) 295-2084

www.pennengineering.com

Ordering Information - To order use the following example:

Model 4742-11B12N.....is a WR-90 Twistable Flex section 12" long w/ Neoprene Jacket and brass cover flanges



ALLOY: A=ALUMINUM B=BRASS

FLANGE: 1=COVER 2=CHOKE 3=CMR 4=CPRG 5=CPRF

JACKET: N=NEOPRENE P=POLYSULFIDE (BRUSH-ON) S=SILICONE V=VINYL (BRUSH-ON)

(See last page for complete list of flanges, materials, and finishes)

29045 Avenue Penn
 Valencia, California
 91355-5426

(661) 295-2080

FAX (661) 295-2084

www.pennengineering.com

FLEXIBLE TWISTABLE WAVEGUIDE SPECIFICATIONS

Typical Electrical Specifications				Typical Mechanical Specifications				Power Handling		
MODEL NO.	EIA W/R SIZE	FREQ. RANGE GHz	*VSWR	**ATTEN.	Band Radii to Centerline				Power (Watts)	Peak Power (KW)
					With Jacket (in Inches)		Without Jacket (in Inches)			
					E-Plane	H-Plane	E-Plane	H-Plane		
4728	22	33.0-50.0	1.35	1.200	.75	1.13	.44	.94	25	12
4730	28	26.5-40.0	1.30	0.600	.75	1.13	.44	.94	75	20
4732	34	22.0-33.0	1.30	0.500	.75	1.13	.44	.94	100	30
4734	42	18.0-26.5	1.20	0.350	.88	1.25	.57	.88	100	39
4736	51	15.0-22.0	1.21	0.210	.90	1.40	.63	1.0	300	70
4738	62	12.4-18.0	1.12	0.200	1.00	1.88	.69	1.25	400	100
4740	75	10.0-15.0	1.12	0.150	1.13	2.25	.63	1.25	750	140
4742	90	8.20-12.4	1.10	0.100	1.75	2.50	1.25	1.50	1,000	180
4744	102	7.00-11.0	1.10	0.090	2.00	2.88	1.30	1.94	1,500	300
4746	112	7.05-10.0	1.10	0.080	2.25	3.25	1.40	1.82	1,500	315
4748	137	5.85-8.20	1.09	0.070	2.38	3.38	1.50	2.07	2,000	500
4750	159	4.90-7.05	1.09	0.060	4.00	6.00	1.60	2.25	2,500	1,100
4752	187	3.95-5.85	1.09	0.050	4.38	6.50	1.94	3.00	3,000	1,250
4754	229	3.30-4.90	1.07	0.023	6.50	8.00	2.13	3.25	4,000	1,550
4756	284	2.60-3.95	1.09	0.018	7.00	9.50	2.94	5.50	4,000	2,000
4758	340	2.20-3.30	1.07	0.010	10.0	16.0	4.25	6.00	8,000	3,700
4760	430	1.70-2.60	1.07	0.010	12.0	25.0	4.82	6.63	10,000	4,700
4764	650	1.12-1.70	1.06	0.005	20.0	40.0	14.0	28.0	10,000	10,700

*VSWR is per 2 Ft. Section

**Attenuation (Insertion Loss) is dB per Ft.

Mechanical Specifications are approximate for Flexible Twistable Waveguide.

PRESSURIZING SECTIONS

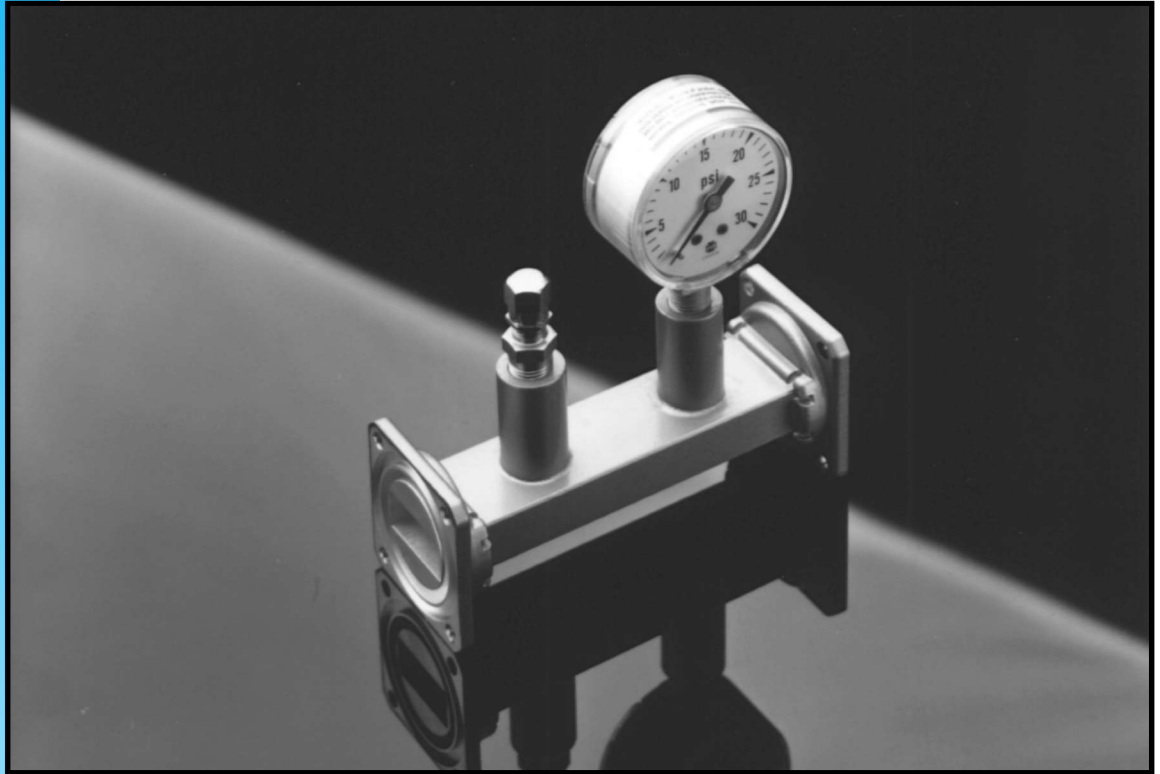

PENN ENGINEERING'S Pressure Sections are used where air or other gases are to be introduced into the waveguide system. Stainless Steel Schrader valves are supplied as standard for inlets for air/gasses. Pressure Gauges are supplied in either 0-15 PSI or 0-30 PSI ranges to monitor internal pressure. Standard Pressure Ports have 1/8-27 NPT threaded receptacles and are 1.06 VSWR typ.

As Standard, Aluminum Pressure Sections are Chem-Filmed per MIL-DTL-5541, and all are finished with PENN ENGINEERING'S Polyurethane Blue/Gray Paint.

We will build custom Pressurizing Sections to your specifications.

PENN ENGINEERING COMPONENTS

29045 Avenue Penn
Valencia, California
91355-5426

(661) 295-2080

FAX (661) 295-2084

www.pennengineering.com

ORDERING INFORMATION - TO ORDER, USE THE FOLLOWING EXAMPLE:

MODEL 4142-11B15-NB Is a WR-90 unit with cover/cover flanges in copper alloy material with a 15 psi pressure gauge

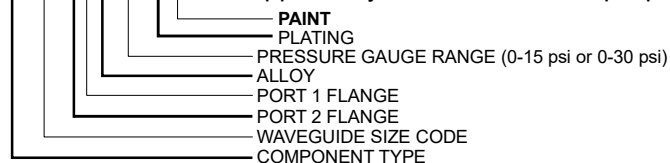

ALLOY: A=ALUMINUM B=BRASS C=COPPER S=SILVER SS=STAINLESS STEEL
FLANGE: 1=COVER 2=CHOKE 3=CMR 4=CPRG 5=CPRF

(See last page for complete list of flanges, materials, and finishes)

PRESSURIZING SECTIONS

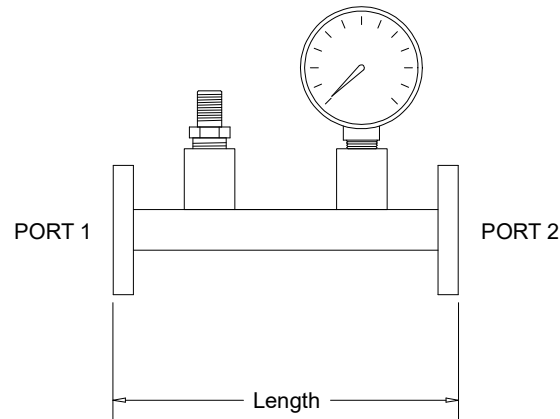

Model No.	Waveguide Size EIA	Frequency Range GHz	Length
4156	WR 284	2.60-3.95	6.00
4154	WR 229	3.30-4.90	6.00
4152	WR 187	3.95-5.85	5.00
4150	WR 159	4.90-7.05	5.00
4148	WR 137	5.85-8.20	4.25
4146	WR 112	7.05-10.0	4.25
4144	WR 102	7.00-11.0	4.25
4142	WR 90	8.20-12.4	4.25
4140	WR 75	10.00-15.0	4.25
4138	WR 62	12.4-18.0	4.25
4136	WR 51	15.0-22.0	4.25
4134	WR 42	18.0-26.5	4.25
4132	WR 34	22.0-33.0	4.25
4130	WR 28	26.5-40.0	4.25
4128	WR 22	33.0-50.0	4.25
4126	WR 19	40.0-60.0	4.25
4124	WR 15	50.0-75.0	4.25
4122	WR 12	60.0-90.0	4.25
4120	WR 10	75.0-110.0	4.25

PENN
ENGINEERING
COMPONENTS

29045 Avenue Penn
Valencia, California
91355-5426

(661) 295-2080

FAX (661) 295-2084

www.pennengineering.com

RF GASKETS

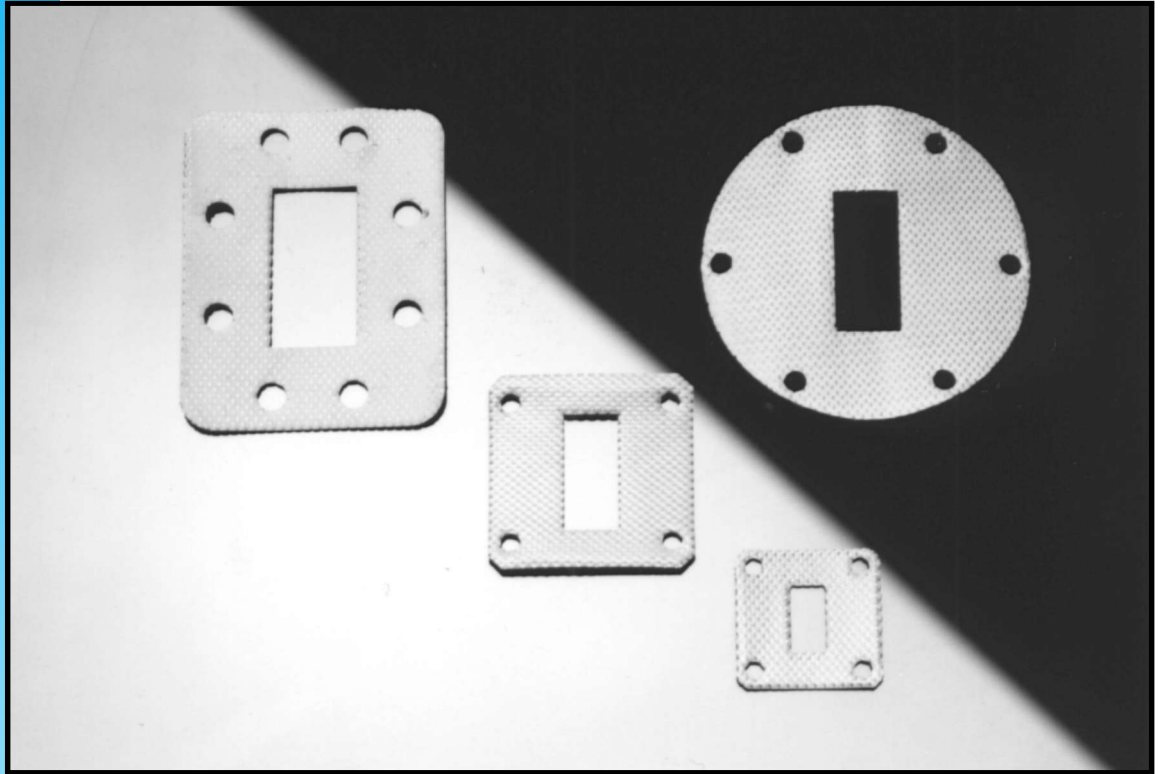

PENN ENGINEERING offers a line of RF waveguide flange gaskets to prevent RF leakage. The material is a high quality MIL-grade silicone filled expanded Monel.

Temperature range is -80 F to +400 F (-62 C to +204 C).

Styles are available in UG, CMR, and CPR types. We will quote you on your custom RF gaskets.

PENN ENGINEERING COMPONENTS

29045 Avenue Penn
Valencia, California
91355-5426

(661) 295-2080

FAX (661) 295-2084

www.pennengineering.com

ORDERING INFORMATION - TO ORDER, USE THE FOLLOWING EXAMPLE:

MODEL 6242-5..... Is for a WR-90 CPR style flange.

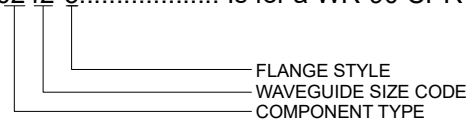

FLANGE STYLE: 1=COVER 2=CHOKE 3=CMR 4=CPRG 5=CPRF

RF GASKETS

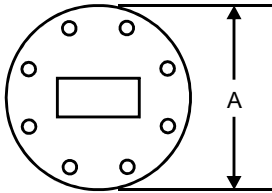

Fig. 1

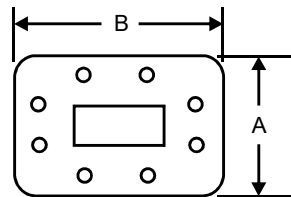

Fig. 2

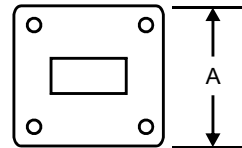
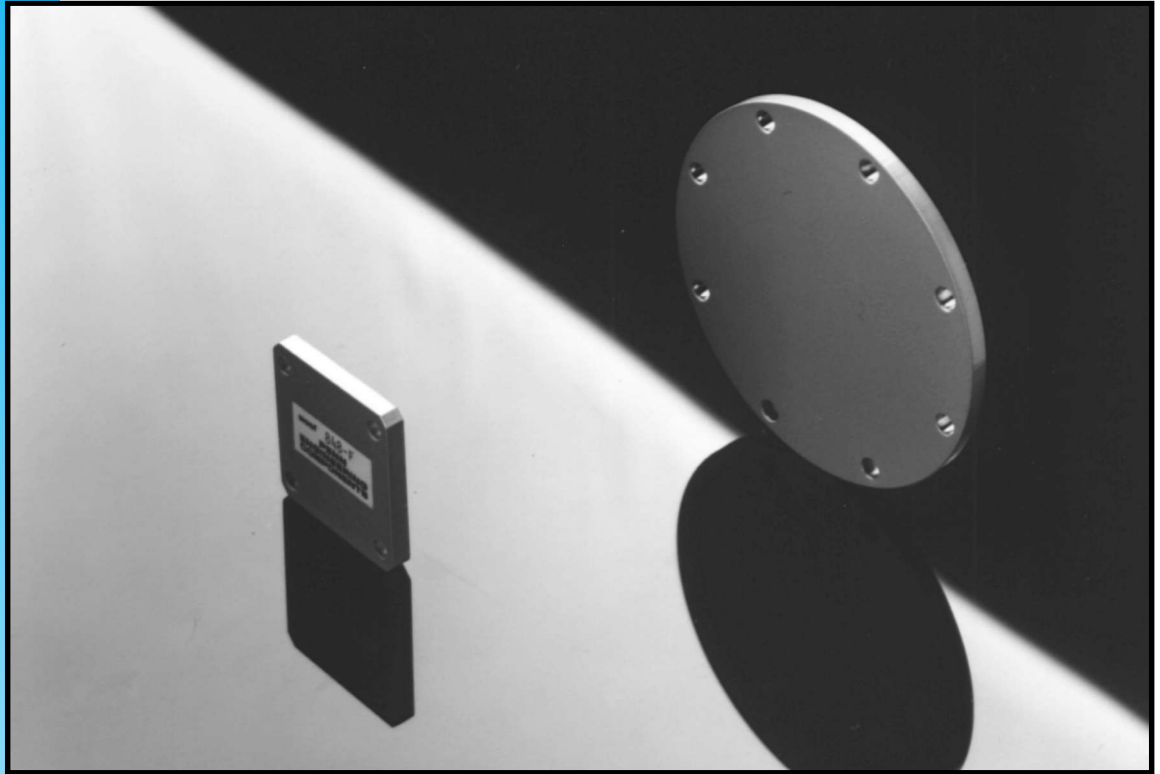

Fig. 3

Model	Waveguide EIA	Frequency	Flange Style	Fig.	A (inches)	B (inches)
6264-5	WR-650	1.12-1.17	UG-1720/CPR	2	5-7/16	8-11/16
6260-5	WR-430	1.70-2.60	UG-1711/CPR	2	4-3/16	6-11/32
6256-1	WR-284	2.60-3.95	UG-53/U	1	5-5/16	-
6256-3			CMR-284	2	2-11/32	3-27/32
6256-5			CPR-284	2	3	4-1/2
6254-3	WR-229	3.30-4.90	CMR-229	2	2	3-5/32
6254-5			CPR-229	2	2-3/4	3-7/8
6252-1	WR-187	3.95-3.85	UG-149A/U	1	3-5/8	-
6252-3			CMR-187	2	1-25/32	2-25/32
6252-5			CPR-187	2	2-1/2	3-1/2
6250-3	WR-159	4.90-7.05	CMR-159	2	1-3/4	2-1/2
6250-5			CPR-159	2	2-7/16	3-3/16
6248-1	WR-137	5.82-8.20	UG-344/U	1	3-1/8	-
6248-3			CMR-137	2	1-17/32	2-9/32
6248-5			CPR-137	2	1-15/16	2-11/16
6246-1	WR-112	7.05-10.0	UG-51/U	3	1-7/8	-
6246-3			CMR-112	2	1-3/8	2-1/64
6246-5			CPR-112	2	1-3/4	2-1/2
6244-1	WR-102	7.00-11.0	UG-1493/U	3	1-11/16	-
6242-1	WR-90	8.20-12.4	UG-39/U	3	1-5/8	-
6242-3			CMR-90	2	1-17/64	1-49/64
6242-5			CPR-90	2	1-19/32	2-3/32
6240-1	WR-75	10.0-15.0	WR-75	3	1-1/2	-
6238-1	WR-62	12.4-18.0	UG-419/U	3	1-15/16	-
6236-1	WR-51	15.0-22.0	WR-51	3	1-13/16	-
6234-1	WR-42	18.0-26.5	UG-595/U	3	7/8	-
6232-1	WR-34	22.0-33.0	UG-1530/U	3	7/8	-
6230-1	WR-28	26.5-40.0	UG-599/U	3	3/4	-

SHORTING PLATES



PENN ENGINEERING offers a line of Shorting Plates which provide almost perfect RF reflection. They are also used with gaskets to seal waveguide for pressure testing purposes. Other Shorts are available in various styles such as UG, CPR/CPRG, CMR, European style, and Double Ridge.

We will also make custom Shorting Plates to your specifications.

As Standard, Aluminum Shorting Plates are Chem-Filmed per MIL-DTL-5541, and all are finished with PENN ENGINEERING'S Polyurethane Blue/Gray Paint.

PENN ENGINEERING COMPONENTS

29045 Avenue Penn
Valencia, California
91355-5426

(661) 295-2080

FAX (661) 295-2084

www.pennengineering.com

ORDERING INFORMATION - TO ORDER, USE THE FOLLOWING EXAMPLE:

MODEL 6142-1B-NB Is a WR-90 Shorting Plate cover flange style in brass with no plating and standard paint

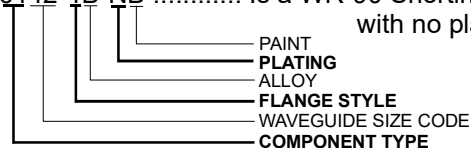

ALLOY: A=ALUMINUM B=BRASS C=COPPER S=SILVER SS=STAINLESS STEEL
FLANGE STYLE: 1=COVER 2=CHOKE 3=CMR 4=CPRG 5=CPRF

(See last page for complete list of flanges, materials, and finishes)

SHORTING PLATES

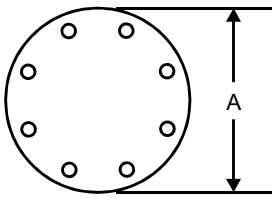

Fig. 1

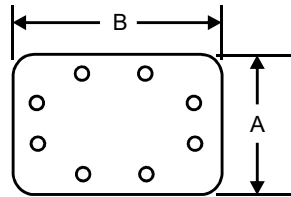

Fig. 2

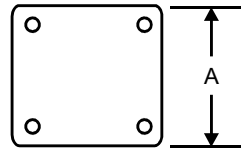

Fig. 3

SHORTING PLATES ARE .187 THICK TYP.

Model Number	Waveguide EIA	Frequency range (GHz)	Flange	Fig.	Dimension "A"	Dimension "B"
6164-5	WR 650	1.12-1.70	UG Style	2	5.437	8.687
6160-5	WR 430	1.70-2.60	UG Style	2	4.187	6.343
6156-1	WR 284	2.60-3.95	UG Style	1	5.312	—
6156-3			CMR-284	2	2.343	3.843
6156-5			CPR-284	2	3	4.5
6154-3	WR 229	3.30-4.90	CMR-229	2	2	3.156
6154-5			CPR-229	2	2.75	3.875
6152-1	WR 187	3.95-3.85	UG Style	1	3.625	—
6152-3			CMR-187	2	1.781	2.781
6152-5			CPR-187	2	2.5	3.5
6150-3	WR 159	4.90-7.05	CMR-159	2	11.75	2.5
6150-5			CPR-159	2	2.437	3.187
6148-1	WR 137	5.85-8.20	UG Style	1	3.125	—
6148-3			CMR-137	2	1.531	2.281
6148-5			CPR-137	2	1.312	2.687
6146-1	WR 112	7.05-10.0	UG Style	3	1.875	—
6146-3			CMR-112	2	1.375	2.015
6146-5			CPR-112	2	1.75	2.5
6144-1	WR 102	7.00-11.0	UG Style	3	1.687	—
6142-1	WR 90	8.20-12.4	UG Style	3	1.625	—
6142-3			CMR-90	2	1.265	1.765
6142-5			CPR-90	2	1.593	2.093
6140-1	WR 75	10.0-15.0	WR 75	3	1.5	—
6140-5			CPR-75	2	1.325	1.7
6138-1	WR 62	12.4-18.0	UG Style	3	1.312	—
6136-1	WR 51	15.0-22.0	WR 51	3	1.187	—
6134-1	WR 42	18.0-26.5	UG Style	3	0.875	—
6132-1	WR 34	22.0-33.0	UG Style	3	0.875	—
6130-1	WR 28	26.5-40.0	UG Style	3	0.75	—
6128-1	WR 22, 19	33.0-60.0	UG Style	1	1.125	—
6124-1	WR 15, 12, 10	50.0-110.0	UG Style	1	0.75	—
6184-1	WRD 350	3.50-8.20	—	2	2	2.75
6190-1	WRD 650	6.5-18.0	—	3	1.375	—
6192-1	WRD 750	7.50-18.0	—	3	1.375	—

PENN
ENGINEERING
COMPONENTS

29045 Avenue Penn
Valencia, California
91355-5426

(661) 295-2080

FAX (661) 295-2084

www.pennengineering.com

STANDARD GAIN HORNS

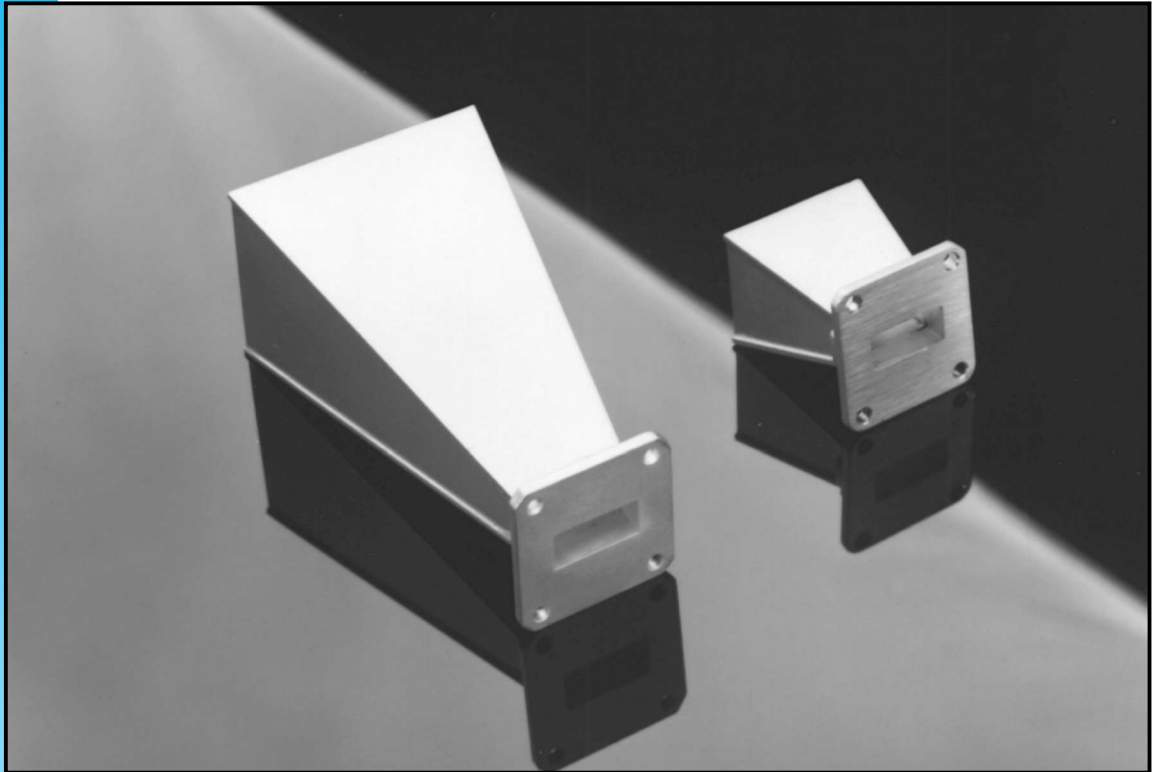

Standard Gain Horns are available with mid-band gains of 10, 15, or 20 dB. The beam width of these horns is approximately 50 degrees for 10 dB, 32 degrees for 15 dB and 15 degrees for 20 dB. Typical VSWR is 1.5:1 Max.

As Standard, Aluminum Gain Horns are Chem-Filmed per MIL-DTL-5541, and all are finished with PENN ENGINEERING'S Polyurethane Blue/Gray Paint.

Gains and beam widths other than those listed are available upon request.

PENN ENGINEERING COMPONENTS

29045 Avenue Penn
Valencia, California
91355-5426

(661) 295-2080

FAX (661) 295-2084

www.pennengineering.com

ORDERING INFORMATION - TO ORDER, USE THE FOLLOWING EXAMPLE:

MODEL 9042-1B15-NB Is a WR-90 15 dB Horn with a cover flange in brass

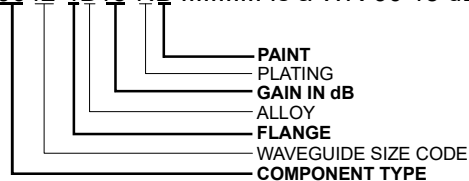

ALLOY: A=ALUMINUM B=BRASS C=COPPER S=SILVER SS=STAINLESS STEEL
FLANGE: 1=COVER 2=CHOKE 3=CMR 4=CPRG 5=CPRF

(See last page for complete list of flanges, materials, and finishes)

STANDARD GAIN HORNS

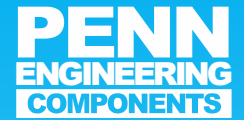

29045 Avenue Penn
Valencia, California
91355-5426

(661) 295-2080

FAX (661) 295-2084

www.pennengineering.com

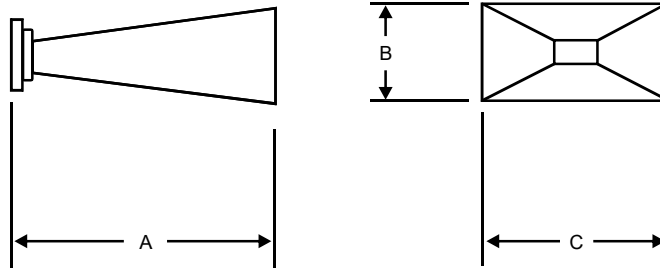

Model No.	WR Size	Frequency (GHz)	10 dB Gain			15 dB Gain			20 dB Gain		
			A	B	C	A	B	C	A	B	C
9060	WR 430	1.70-2.60	10.5	4	8	23.72	9.4	12.8	on	request	
9058	WR 340	2.20-3.30	on	request							
9056	WR 284	2.60-3.95	7.5	3.46	4.72	15.34	5.83	7.96	29.75	10.67	15.57
9054	WR 229	3.30-4.90	on	request							
9052	WR 187	3.95-5.85	5.4	2.12	2.89	9.4	3.57	4.88	15.05	6.53	8.92
9050	WR 159	4.90-7.05	on	request							
9048	WR 137	5.85-8.20	3.15	1.48	2.02	6.51	2.5	3.42	12.19	4.57	6.26
9046	WR 112	7.05-10.0	2.55	1.18	1.63	5.21	1.99	2.75	10.78	3.64	4.97
9044	WR 102	7.00-11.0	on	request							
9042	WR 90	8.20-12.4	2.01	1.15	1.58	5.46	1.95	2.66	10.06	3.62	4.87
9040	WR 75	10.0-15.0	1.94	0.92	1.26	4.69	1.33	2.25	8	2.98	3.88
9038	WR 62	12.4-18.0	1.61	0.68	0.93	3.31	1.15	1.57	5.75	2.11	2.88
9036	WR 51	15.0-22.0	on	request							
9034	WR 42	18.0-26.5	1.25	0.44	0.6	2.37	0.75	1.02	4	1.36	1.86
9032	WR 34	22.0-33.0	on	request							
9030	WR 28	26.5-40.0	1	0.33	0.45	1.87	0.55	0.76	3.12	1.01	1.38

dimensions are in inches

Typical Radiation Patterns

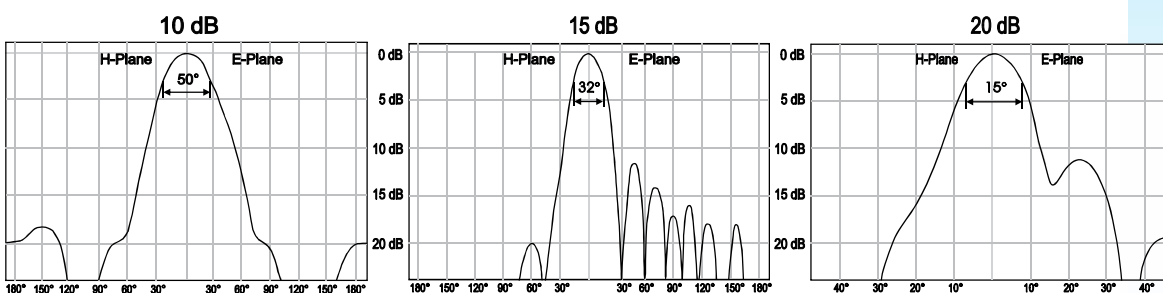

WAVEGUIDE STRAIGHT SECTIONS

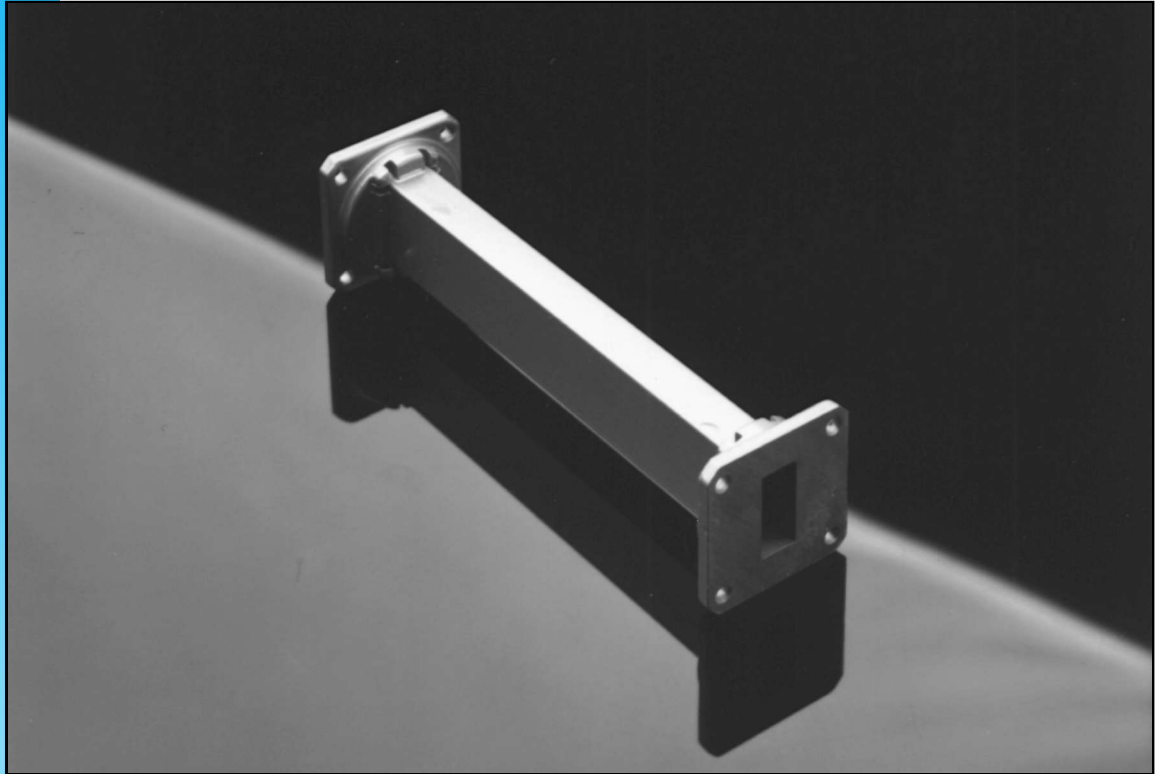

PENN ENGINEERING offers Straight Waveguide Section/Flange Adapters with almost any flange combination. Straight Sections are available in various materials such as OFHC Copper, 90-10 Bronze, Aluminum, Silver, Invar, and Stainless Steel.

As Standard, Aluminum Straight Sections are Chem-Filmed per MIL-DTL-5541, and all are finished with PENN ENGINEERING'S Polyurethane Blue/Gray Paint.

Overall **Length** is specified in part number.

Note: Stainless Steel and Invar Straight Sections have Brass Flanges and no plate or paint as standard. Copper Straight Sections are Painted, but not Plated as standard. Special finishes and flanges are available on request.

PENN ENGINEERING COMPONENTS

29045 Avenue Penn
Valencia, California
91355-5426

(661) 295-2080

FAX (661) 295-2084

www.pennengineering.com

ORDERING INFORMATION - TO ORDER, USE THE FOLLOWING EXAMPLE:

MODEL 4042-11B12.5-NB.....Is a WR-90 straight section cover/cover in brass 12.5" long with no plating and standard paint

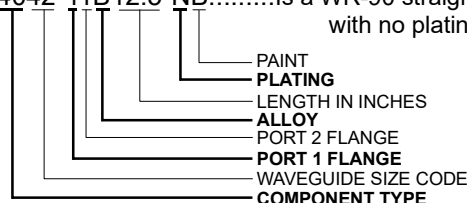

ALLOY: A=ALUMINUM B=BRASS C=COPPER S=SILVER SS=STAINLESS STEEL
FLANGE: 1=COVER 2=CHOKE 3=CMR 4=CPRG 5=CPRF

(See last page for complete list of flanges, materials, and finishes)

29045 Avenue Penn
 Valencia, California
 91355-5426

(661) 295-2080

FAX (661) 295-2084

www.pennengineering.com

STRAIGHT SECTIONS

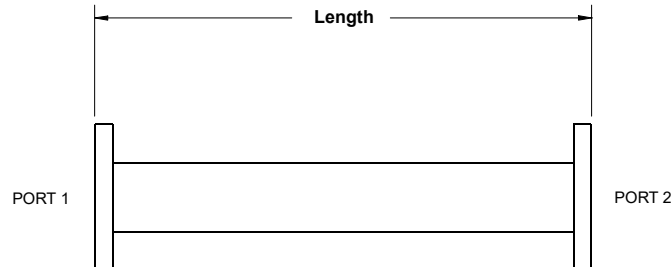

Model No.	Waveguide EIA	Frequency range GHz
4064	WR 650	1.12 - 1.70
4062	WR 510	1.45 - 2.20
4060	WR 430	1.70 - 2.60
4058	WR 340	2.20 - 3.30
4056	WR 284	2.60 - 3.95
4054	WR 229	3.30 - 4.90
4052	WR 187	3.95 - 5.85
4050	WR 159	4.90 - 7.05
4048	WR 137	5.85 - 8.20
4046	WR 112	7.05 - 10.0
4044	WR 102	7.00 - 11.0
4042	WR 90	8.20 - 12.4
4040	WR 75	10.0 - 15.0
4038	WR 62	12.4 - 18.0
4036	WR 51	15.0 - 22.0
4034	WR 42	18.0 - 26.5
4032	WR 34	22.0 - 33.0
4030	WR 28	26.5 - 40.0
4028	WR 22	33.0 - 50.0
4026	WR 19	40.0-60.0
4024	WR 15	50.0 - 75.0
4022	WR 12	60.0 - 90.0
4020	WR 10	75.0 - 110.0

TEES - WAVEGUIDE

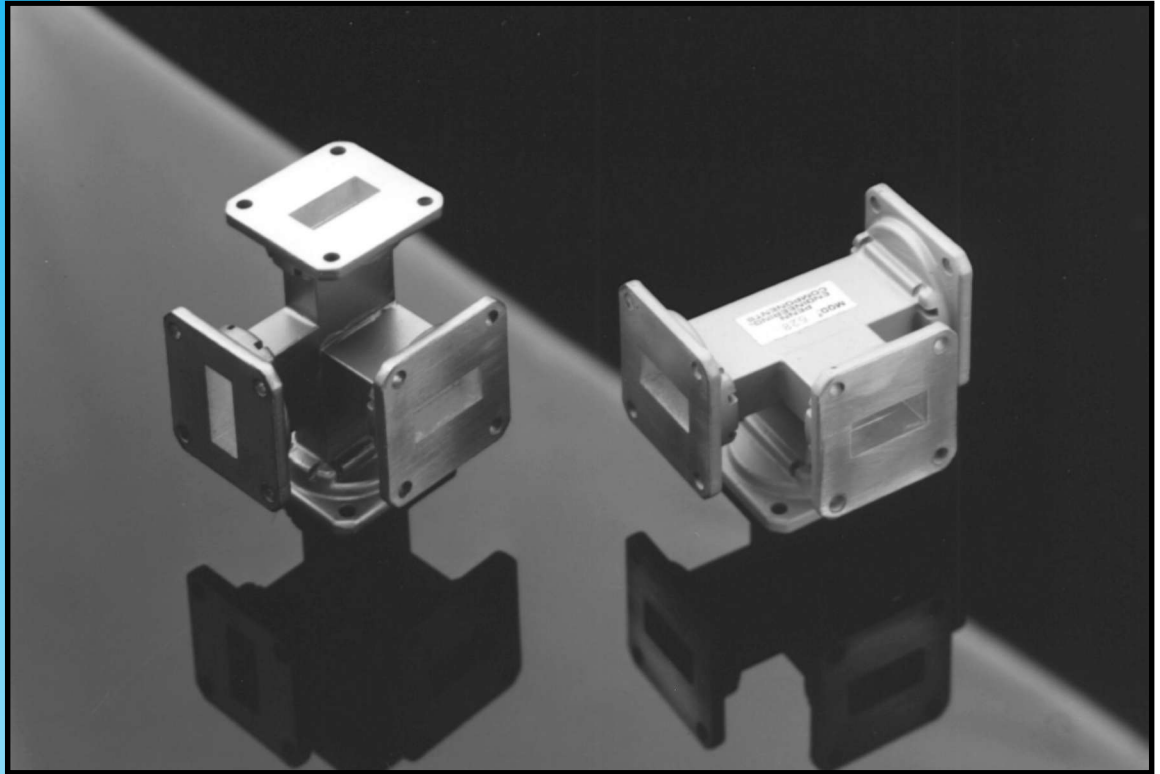

PENN ENGINEERING'S line of Waveguide Tees are excellent for adding components in a test situation. Tees are unmatched as standard. Matched tees are available upon request.

We will also make Custom Waveguide Tees to your specifications.

As Standard, Aluminum Tees are Chem-Filmed per MIL-DTL-5541, and all are finished with PENN ENGINEERING'S Polyurethane Blue/Gray Paint.

PENN ENGINEERING COMPONENTS

29045 Avenue Penn
Valencia, California
91355-5426

(661) 295-2080

FAX (661) 295-2084

www.pennengineering.com

ORDERING INFORMATION - TO ORDER, USE THE FOLLOWING EXAMPLE:

MODEL 8242-1111B-NB...is a WR-90 hybrid model with cover flanges on all ports in brass with no plating and standard paint

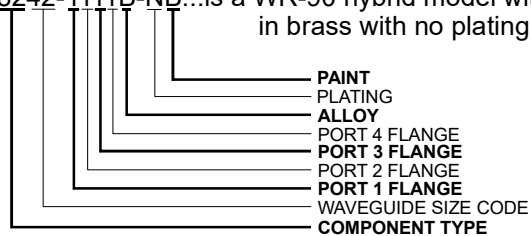

ALLOY: A=ALUMINUM B=BRASS C=COPPER S=SILVER SS=STAINLESS STEEL
FLANGE: 1=COVER 2=CHOKE 3=CMR 4=CPRG 5=CPRF 6=SMA 7=TYPE N

(See last page for complete list of flanges, materials, and finishes)

29045 Avenue Penn
 Valencia, California
 91355-5426

(661) 295-2080

FAX (661) 295-2084

www.pennengineering.com

TEES-WAVEGUIDE

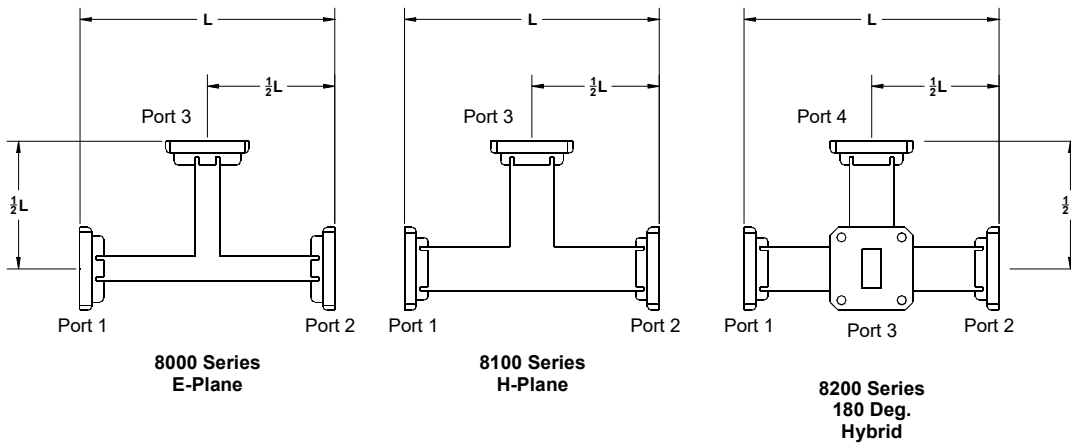

Series (E-plane) Model #	Shunt (H-plane) Model #	Hybrid (E and H) Model#	Waveguide Size	Frequency GHz	"L" (inches)
8064	8164	8264	WR 650	1.12-1.70	10.5
8060	8160	8260	WR 430	1.70-2.60	9
8056	8156	8256	WR 284	2.60-3.95	7.5
8054	8154	8254	WR 229	3.30-4.90	6.5
8052	8152	8252	WR 187	3.95-5.85	5.75
8050	8150	8250	WR 159	4.90-7.05	5.25
8048	8148	8248	WR 137	5.85-8.20	5.125
8046	8146	8246	WR 112	7.05-10.0	3.312
8044	8144	8244	WR 102	7.00-11.0	3.25
8042	8142	8242	WR 90	8.20-12.4	3.125
8040	8140	8240	WR 75	10.0-15.0	2.75
8038	8138	8238	WR 62	12.4-18.0	2.625
8036	8136	8236	WR 51	15.0-22.0	2.375
8034	8134	8234	WR 42	18.0-26.5	2.5
8032	8132	8232	WR 34	22.0-33.0	2.5
8030	8130	8230	WR 28	26.5-40.0	2.375
8028	8128	8228	WR 22	33.0-50.0	2.375
8026	8126	8226	WR 19	40.0-60.0	2.375
8024	8124	8224	WR 15	50.0-75.0	2.375
8022	8122	8222	WR 12	60.0-90.0	2.375
8020	8120	8220	WR 10	75.0-110.0	2.375

TERMINATIONS-FIXED, LOW POWER



PENN ENGINEERING'S Low Power Terminations are a low VSWR (1.02:1 typ.) component used to terminate a waveguide run and for electrical testing/calibration.

As Standard, Aluminum Terminations are Chem-Filmed per MIL-DTL-5541, and all are finished with PENN ENGINEERING'S Polyurethane Blue/Gray Paint.

PENN ENGINEERING COMPONENTS

29045 Avenue Penn
Valencia, California
91355-5426

(661) 295-2080

FAX (661) 295-2084

www.pennengineering.com

ORDERING INFORMATION - TO ORDER, USE THE FOLLOWING EXAMPLE:

MODEL 7142-1B-NB..... Is a WR-90 Termination with a cover flange in brass

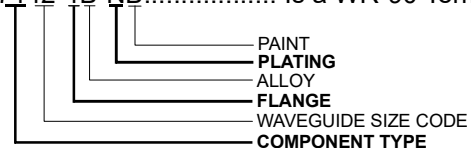

ALLOY: A=ALUMINUM B=BRASS C=COPPER S=SILVER SS=STAINLESS STEEL
FLANGE: 1=COVER 2=CHOKE 3=CMR 4=CPRG 5=CPRF

(See last page for complete list of flanges, materials, and finishes)

TERMINATIONS FIXED, LOW POWER

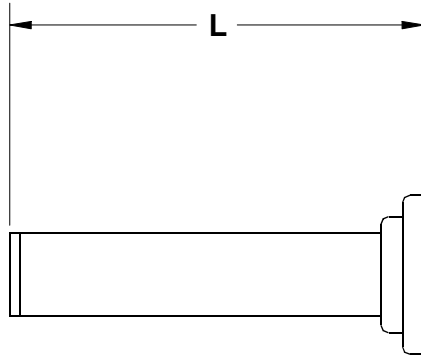

PENN
ENGINEERING
COMPONENTS

29045 Avenue Penn
Valencia, California
91355-5426

(661) 295-2080

FAX (661) 295-2084

www.pennengineering.com

Model No.	Waveguide size (EIA)	Frequency Range (GHz)	Average Watts	VSWR typ.	"L"
7160	WR 430	1.70-2.60	<i>on</i>	<i>request</i>	
7158	WR 340	2.20-3.30	<i>on</i>	<i>request</i>	
7156	WR 284	2.50-3.95	10	1.02	11.00
7154	WR 229	3.30-4.90	10	1.02	8.00
7152	WR 187	3.95-5.85	8	1.02	6.50
7150	WR 159	4.90-7.05	5	1.02	5.75
7148	WR 137	5.85-8.20	6	1.02	6.25
7146	WR 112	7.05-10.0	5	1.02	4.75
7144	WR 102	7.00-11.0	5	1.02	3.75
7142	WR 90	8.20-12.4	4	1.02	3.50
7140	WR 75	10.0-15.0	2.5	1.02	3.75
7138	WR 62	12.4-18.0	1.5	1.02	3.37
7136	WR 51	15.0-22.0	1	1.02	3.12
7134	WR 42	18.0-26.5	1	1.02	3.00
7132	WR 34	22.0-33.0	1	1.02	2.50
7130	WR 28	26.5-40.0	0.5	1.02	2.37
7128	WR 22	33.0-50.0	0.25	1.02	2.37
7126	WR 19	40.0-60.0	0.25	1.02	2.00
7124	WR 15	50.0-75.0	0.125	1.02	2.00
7122	WR 12	60.0-90.0	0.125	1.02	2.00

TERMINATIONS-FIXED, MEDIUM POWER



PENN ENGINEERING'S Medium Power Terminations are a low VSWR component used to terminate a waveguide run and for electrical testing/calibration.

As Standard, Aluminum Terminations are Chem-Filmed per MIL-DTL-5541, and all are finished with PENN ENGINEERING'S Polyurethane Blue/Gray Paint.

PENN ENGINEERING COMPONENTS

29045 Avenue Penn
Valencia, California
91355-5426

(661) 295-2080

FAX (661) 295-2084

www.pennengineering.com

ORDERING INFORMATION - TO ORDER, USE THE FOLLOWING EXAMPLE:

MODEL 7242-1B-NB..... Is a WR-90 Medium-Power Termination with a cover flange
in brass with no plating and standard paint

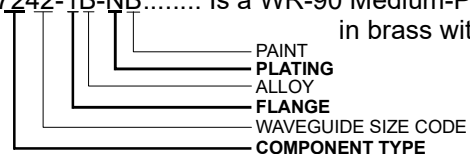

ALLOY: A=ALUMINUM B=BRASS C=COPPER S=SILVER SS=STAINLESS STEEL
FLANGE: 1=COVER 2=CHOKE 3=CMR 4=CPRG 5=CPRF

(See last page for complete list of flanges, materials, and finishes)

29045 Avenue Penn
 Valencia, California
 91355-5426

(661) 295-2080

FAX (661) 295-2084

www.pennengineering.com

TERMINATIONS FIXED, MEDIUM POWER

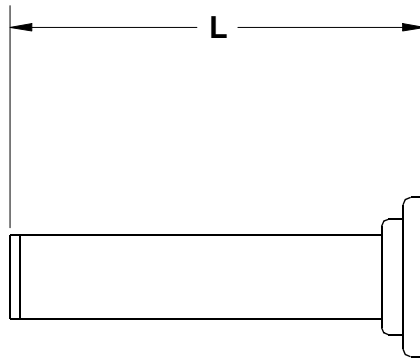

Model No.	Waveguide size (EIA)	Frequency Range (GHz)	Average Watts	VSWR typ.	"L"
7252	WR 187	3.95-5.85	30	1.04	6.50
7248	WR 137	5.85-8.20	30	1.03	6.25
7246	WR 112	7.05-10.0	50	1.03	4.75
7242	WR 90	8.20-12.4	50	1.03	3.50
7240	WR 75	10.0-15.0	60	1.04	3.75
7238	WR 62	12.4-18.0	60	1.03	3.37
7236	WR 51	15.0-22.0	50	1.04	3.12
7234	WR 42	18.0-26.5	25	1.04	3.37
7232	WR 34	22.0-33.0	25	1.04	2.50
7230	WR 28	26.5-40.0	25	1.04	2.37

TERMINATIONS-FIXED, HIGH POWER

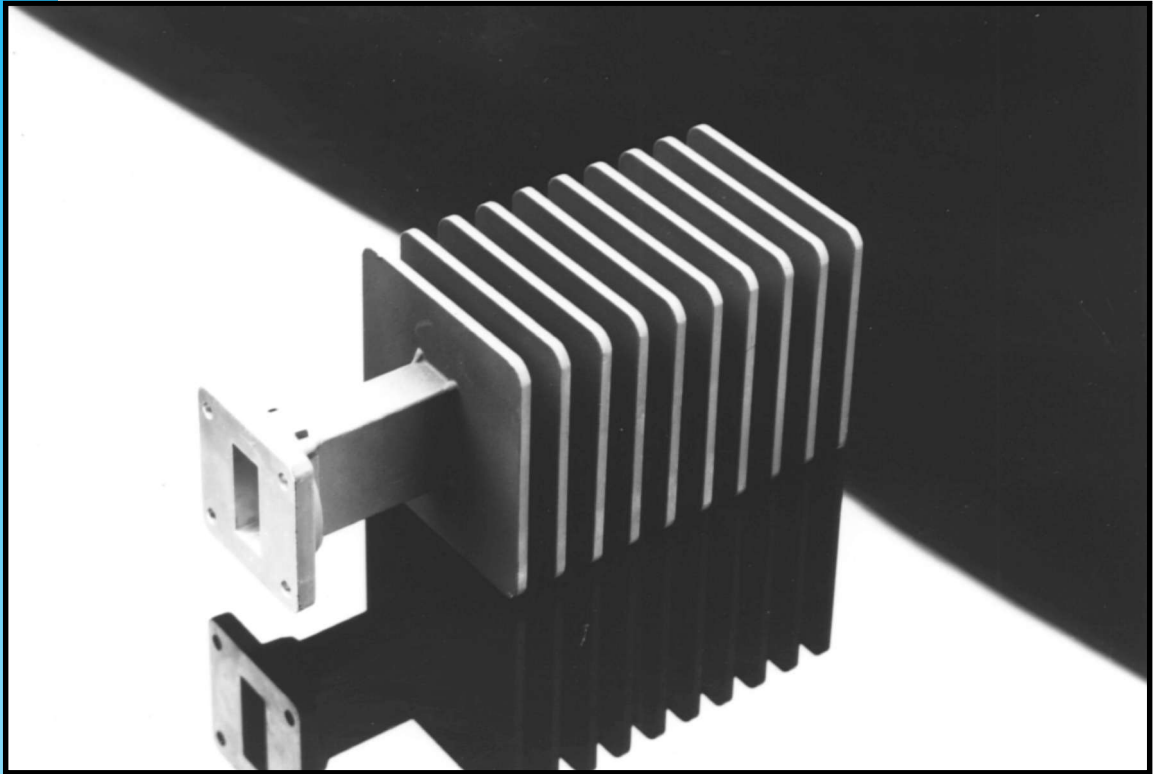

PENN ENGINEERING'S High Power Terminations can terminate a high power waveguide run and still offer a low VSWR (1.10:1 max.). These units are made of premium alloy aluminum and have large cooling fins that dissipate heat efficiently.

We will also design and build custom Terminations to your specifications.

As Standard, High Power Terminations are Chem-filmed per MIL-DTL-5541 and painted Flat Black Polyurethane.

PENN ENGINEERING COMPONENTS

29045 Avenue Penn
Valencia, California
91355-5426

(661) 295-2080

FAX (661) 295-2084

www.pennengineering.com

ORDERING INFORMATION - TO ORDER, USE THE FOLLOWING EXAMPLE:

MODEL 7342-1A-CK Is a WR-90 HP Termination with a cover flange in aluminum with chem-film and standard black paint

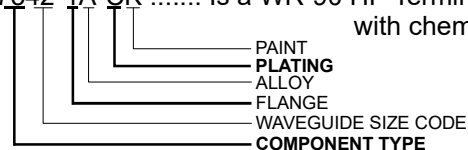

ALLOY: A= ALUMINUM

FLANGE: 1=COVER 2=CHOKE 3=CMR 4=CPRG 5=CPRF

(See last page for complete list of flanges, materials, and finishes)

29045 Avenue Penn
 Valencia, California
 91355-5426

(661) 295-2080

FAX (661) 295-2084

www.pennengineering.com

HIGH POWER TERMINATIONS

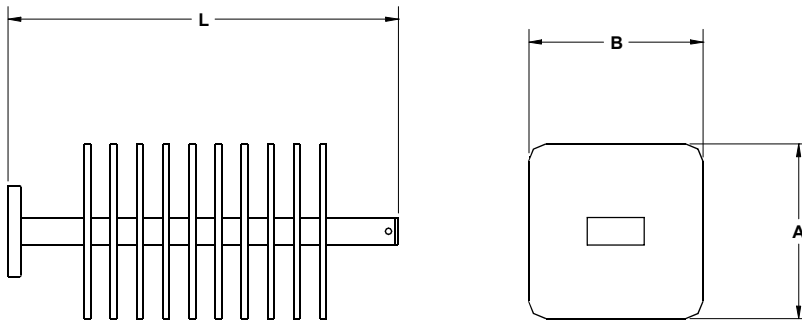

Model #	Waveguide size (EIA)	Frequency (GHz)	Average Power (watts)	Peak Power (kW)	Dim. "L"	Dim. "A"	Dim. "B"
7364	WR650	1.12-1.70	1500	1500	22	11	10.50
7360	WR430	1.70-2.60	1200	1100	<i>on</i>	<i>request</i>	
7358	WR340	2.20-3.30	1000	950	<i>on</i>	<i>request</i>	
7356	WR284	2.60-3.95	1200	950	12	6	5.00
7354	WR229	3.30-4.90	800	750	11	6	5.00
7352	WR187	3.95-5.85	750	750	10	4	3.50
7350	WR159	4.90-7.05	625	625	8.5	4	3.50
7348	WR137	5.85-8.20	500	400	8.5	3.5	3.00
7346	WR112	7.05-10.0	325	300	7.5	3	3.00
7344	WR102	7.00-11.0	125	100	4.5	3	3.00
7342	WR90	8.20-12.4	225	225	6	2.75	2.75
7340	WR75	10.0-15.0	100	90	5	2.5	2.50
7338	WR62	12.4-18.0	250	160	6	2.5	2.50
7336	WR51	15.0-22.0	100	90	5	2	2.00
7334	WR42	18.0-26.5	150	120	4	2	2.00
7332	WR34	22.0-33.0	75	100	5	2	2.00
7330	WR28	26.5-40.0	75	100	5	2	2.00

TRANSITIONS-TAPERED

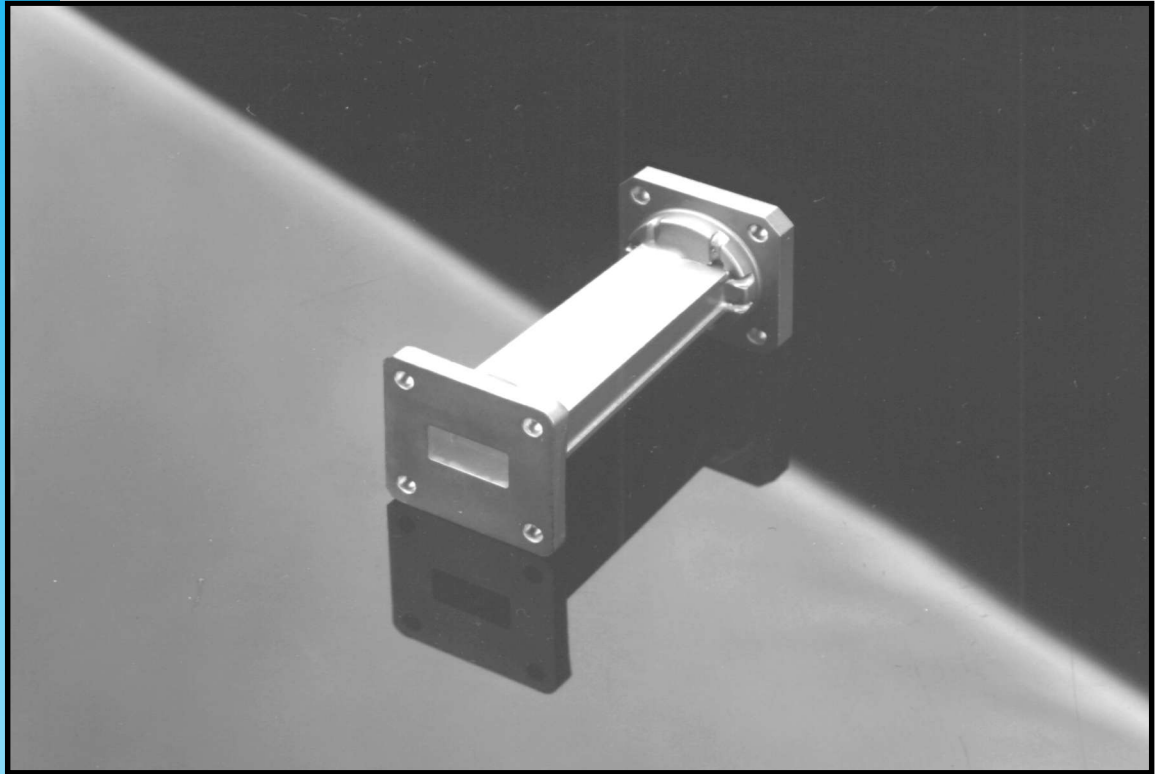

Our Tapered Waveguide Transitions are a means of propagating RF energy from one waveguide size to another.

Standard Transitions are available in 2 Lengths:

The Longer Transitions are for better VSWR (1.05 :1 Typ.)

The Shorter Transitions (VSWR 1.08 :1 Typ.) are for physical requirements

As Standard, Aluminum Transitions are Chem-Filmed per MIL-DTL-5541, and all are finished with PENN ENGINEERING'S Polyurethane Blue/Gray Paint. High frequency Transitions are Gold plated with optional paint.

Other Standard and Custom Transitions are available upon request

PENN ENGINEERING COMPONENTS

29045 Avenue Penn
Valencia, California
91355-5426

(661) 295-2080

FAX (661) 295-2084

www.pennengineering.com

ORDERING INFORMATION - TO ORDER, USE THE FOLLOWING EXAMPLE:

MODEL 4442-11B-NB..... Is a WR-90 to WR-75 Transition with Cover flanges in copper alloy with no plating and standard paint



ALLOY: A=ALUMINUM B=BRASS C=COPPER S=SILVER SS=STAINLESS STEEL
FLANGE: 1=COVER 2=CHOKE 3=CMR 4=CPRG 5=CPRF

(See last page for complete list of flanges, materials, and finishes)

29045 Avenue Penn
 Valencia, California
 91355-5426

(661) 295-2080

FAX (661) 295-2084

www.pennengineering.com

TRANSITIONS -TAPERED

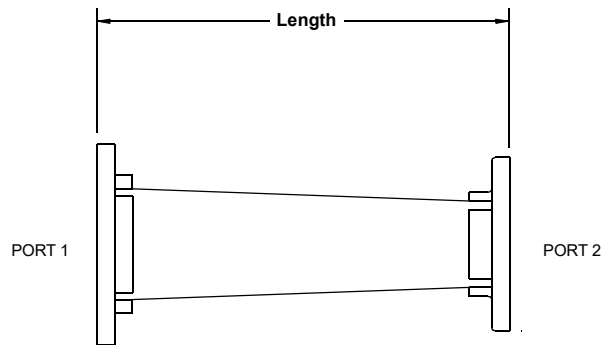

From Size (Port 1)	To Size (Port 2)	Length	Short Model #	Long Model #
WR-284	WR-229	6" or 12"	4456	4556
WR-229	WR-187	6" or 12"	4454	4554
WR-187	WR-159	6" or 12"	4452	4552
WR-159	WR-137	6" or 12"	4450	4550
WR-137	WR-112	6" or 12"	4448	4548
WR-112	WR-90	3" or 6"	4446	4546
WR-102	WR-90	3" or 6"	4444	4544
WR-90	WR-75	3" or 6"	4442	4542
WR-75	WR-62	3" or 6"	4440	4540
WR-62	WR-51	3" or 6"	4438	4538
WR-51	WR-42	3" or 6"	4436	4536
WR-42	WR-34	2" or 4"	4434	4534
WR-34	WR-28	2" or 4"	4432	4532
WR-28	WR-22	2	4430*	—
WR-22	WR-19	1.8	4428*	—
WR-19	WR-15	1.6	4426*	—
WR-15	WR-12	1.4	4424*	—
WR-12	WR-10	1.3	4422*	—
WR-10	WR-8	1.2	4420*	—
WR-8	WR-6	1.1	4418*	—
WR-6	WR-5	1	4416*	—
WR-5	WR-4	1	4414*	—
WR-4	WR-3	0.75	4412*	—

*Electro-Formed and Gold Plated with black finish

dimensions are in inches

TWISTS

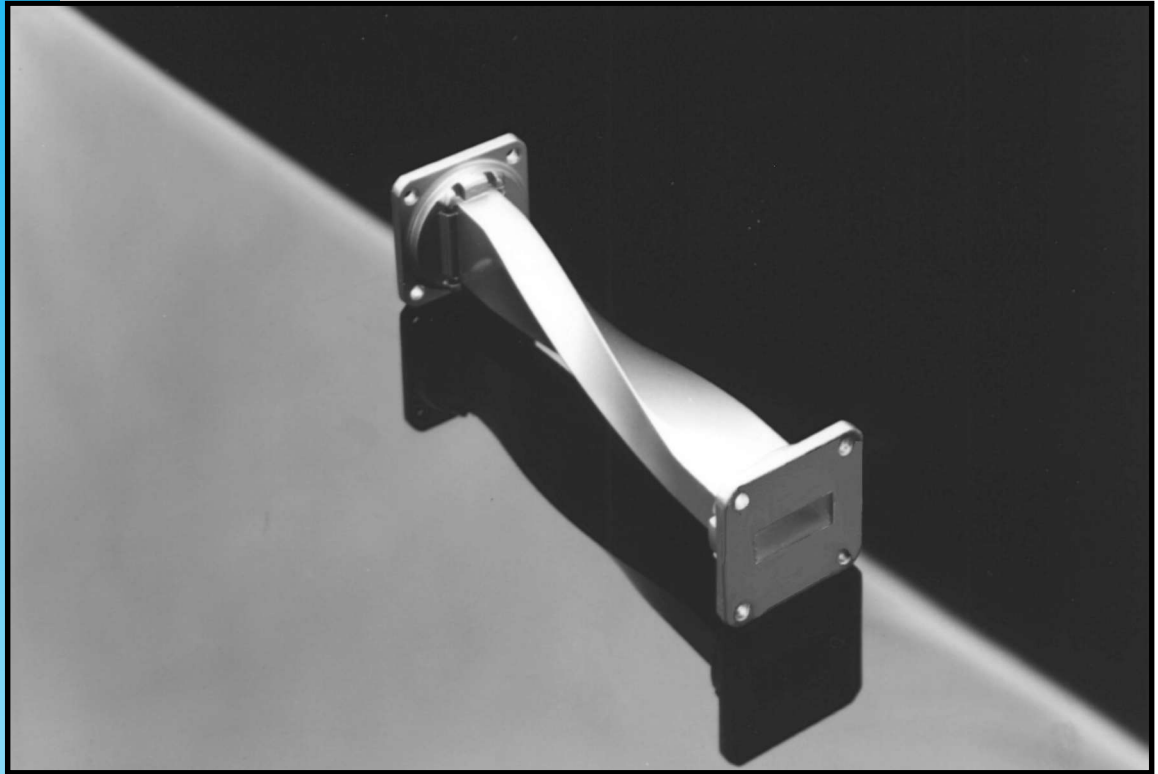

Right-hand twist shown

PENN ENGINEERING offers a line of waveguide Twists for changing the horizontal/vertical orientation of a waveguide system. VSWR is 1.05:1 typ. over the full bandwidth.

As Standard, Aluminum Twists are Chem-Filmed per MIL-DTL-5541, and all are finished with PENN ENGINEERING'S Polyurethane Blue/Gray Paint.

Twists are Left-Handed as standard but can be special ordered right handed. Special Twist angles and lengths are available upon request.

PENN ENGINEERING COMPONENTS

29045 Avenue Penn
Valencia, California
91355-5426

(661) 295-2080

FAX (661) 295-2084

www.pennengineering.com

ORDERING INFORMATION - TO ORDER, USE THE FOLLOWING EXAMPLE:

MODEL 3042-11B-NB Is a WR-90 Twist 90 deg. with cover flanges in brass with no plating and standard paint

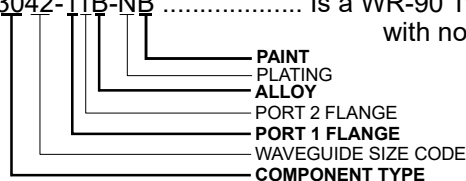

ALLOY: A=ALUMINUM B=BRASS C=COPPER S=SILVER SS=STAINLESS STEEL
FLANGE: 1=COVER 2=CHOKE 3=CMR 4=CPRG 5=CPRF

(See last page for complete list of flanges, materials, and finishes)

TWISTS

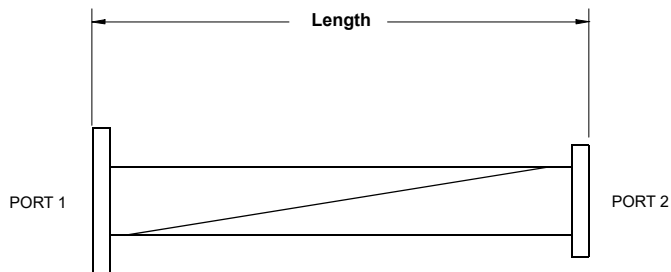

90 Degree Model	45 Degree Model	Waveguide Size	Frequency Range(GHz)	Length
3058	3158	WR 340	2.10-3.00	12.0
3056	3156	WR 284	2.60-3.95	10.0
3054	3154	WR 229	3.30-4.90	10.0
3052	3152	WR 187	3.95-5.85	8.0
3050	3150	WR 159	4.90-7.05	8.0
3048	3148	WR 137	5.85-8.20	8.0
3046	3146	WR 112	7.05-10.0	6.0
3044	3144	WR 102	7.00-11.0	6.0
3042	3142	WR 90	8.20-12.4	6.0
3040	3140	WR 75	10.0-15.0	5.0
3038	3138	WR 62	12.4-18.0	5.0
3036	3136	WR 51	15.0-22.0	4.0
3034	3134	WR 42	18.0-26.5	3.0
3032	3132	WR 34	22.0-33.0	3.0
3030	3130	WR 28	26.5-40.0	3.0
3028	3128	WR 22	33.0-50.0	2.0
3024	3124	WR 15	50.0-75.0	2.0
3022	3122	WR 12	60.0-90.0	2.0
3020	3120	WR 10	75.0-110.0	2.0

Penn Engineering's Standard Component Number Guide

First two numbers:

- 10 = Type N Female end launch
- 11 = Type N Male end launch
- 12 = Type N Female adapter
- 13 = Type N Male adapter
- 14 = SMA Female adapter
- 15 = SMA Male adapter
- 16 = SMA Female end launch
- 17 = SMA Male end launch
- 18 = TNC Female adapter
- 19 = TNC Male adapter
- 20 = 90 degree E bend formed
- 21 = 90 degree H bend formed
- 22 = 45 degree E bend formed (or specified angle)
- 23 = 45 degree H bend formed (or specified angle)
- 24 = 90 degree E bend mitered
- 25 = 90 degree H bend mitered
- 26 = 45 degree E bend mitered
- 27 = 45 degree H bend mitered
- 28 = 180 degree U bend E plane
- 29 = 180 degree U bend H plane
- 30 = 90 degree twist
- 31 = 45 degree twist (or specified angle)
- 32 = S-Bend, E-plane, Formed
- 33 = S-Bend, H-plane, Formed
- 35 = Phase shifter
- 36 = Fixed pad attenuator
- 37 = Variable attenuators
- 38 = S-Bend, E-plane, Mitered
- 39 = S-Bend, H-plane, Mitered
- 40 = Straight Section
- 41 = Waveguide Pressurizing section
- 42 = Bulkhead feed-through
- 43 = Pressure Inlet
- 44 = Waveguide Transition (short models)
- 45 = Waveguide Transition (long models)
- 46 = Flexible Seamless Waveguide Section
- 47 = Flexible Twistable Waveguide Section
- 48 = Flange Spacer
- 49 = Step Transition
- 50 = Top-wall coupler
- 51 = Side-wall coupler
- 52 = Dual Broad-wall coupler
- 53 = Dual cross-guide coupler
- 54 = Cross-guide coupler
- 55 = Cross-guide terminated
- 56 = Power sampler type N Female
- 57 = Power sampler type SMA Female
- 58 = Dual Sidewall Coupler
- 59 = Bi-Directional Top-wall Coupler
- 60 = Pressure window
- 61 = Fixed shorting plate
- 62 = RF flange gasket
- 63 = O-Ring / Gasket
- 64 = Conductive O-Ring/Gasket
- 65 = Shielded O-Ring
- 66 = Flange Adapter
- 67 = Waveguide to Waveguide Adapter
- 68 = Waveguide Hanger
- 71 = Waveguide Termination (low power)
- 72 = Waveguide Termination (medium power)
- 73 = Waveguide Termination (high power)
- 74 = Sliding load
- 75 = Adjustable short
- 76 = Offset Short
- 77 = Short Load
- 78 = Shorting Plate Pressure Inlet
- 80 = E plane series Tee
- 81 = H plane shunt Tee
- 82 = Hybrid Tee
- 90 = Standard gain horn antenna
- 91 = Standard gain horn, Weather Proof
- 92 = Standard gain horn/ Type N Male Adapter
- 93 = Standard gain horn/ Type N Female Adapter
- 94 = Standard gain horn/ Type SMA Male Adapter
- 95 = Standard gain horn/ Type SMA Female Adapter
- 96 = Protective Flange Cover, Plastic
- 97 = Flange hardware kit
- 98 = Flange hardware kit w/ RF gasket
- 99 = Flange hardware kit w/ O-ring/Gasket

Second two numbers:

- 10 = WR 3
- 12 = WR 4
- 14 = WR 5
- 16 = WR 6
- 18 = WR 8
- 20 = WR 10 (W-Band)
- 22 = WR 12
- 24 = WR 15 (V-Band)
- 26 = WR 19 (U-Band)
- 28 = WR 22 (Q-Band)
- 30 = WR 28 (R-Band)
- 32 = WR 34
- 34 = WR 42 (K-Band)
- 36 = WR 51
- 38 = WR 62 (P-Band)
- 40 = WR 75
- 42 = WR 90 (X-Band)
- 44 = WR 102
- 46 = WR 112
- 48 = WR 137 (C-Band)
- 50 = WR 159
- 52 = WR 187
- 54 = WR 229
- 56 = WR 284 (S-Band)
- 58 = WR 340
- 60 = WR 430
- 62 = WR 510
- 64 = WR 650
- 66 = WR 770
- 68 = WR 975
- 70 = WR 1150
- 72 = WR 1800
- 74 = WR 2100
- 76 = WR 2300
- 80 = WRD 180
- 82 = WRD 200
- 84 = WRD 350
- 86 = WRD 475
- 87 = WRD 500
- 88 = WRD 580
- 90 = WRD 650
- 92 = WRD 750
- 94 = WRD 840

Flange Designation(s):

- 0= No flange on Port
- 1= Cover flange
- 2= Choke flange
- 3= CMR flange
- 4= CPRG flange
- 5= CPRF flange
- 6= SMA Female Connector
- 7= Type N Female Connector
- 8= Cover Flange - ALL TAP
- 9= Choke Flange - ALL CLEAR
- C= TNC Female Connector
- D= CPRG ALL TAP
- E= CPRF ALL TAP
- F= CMR w/ all through holes
- G= CMR w/ all tapped holes
- H= PDR flange
- K= PBR flange
- L= UDR flange
- M= UBR flange
- P= PAR flange
- Q= BRJ flange
- R= CBR flange
- T= UER flange
- V= CAR flange
- X= UAR flange
- Y= UG Pressure Cover
- Z= UG Pressure Cover - ALL TAP

ALLOY CODES:

- A= ALUMINUM
- B= BRONZE/BRASS
- C= COPPER
- S= SILVER
- SS= STAINLESS STEEL

FLEX JACKET CODES:

- E= SILICONE (MOLDED)
- K= BLACK PAINT
- N= NEOPRENE (MOLDED)
- S= BRUSH-ON JACKET
- U= NO JACKET
- V= VINYL (BRUSH-ON)

FINISH CODES:

PLATING CODES: C= CHEM-FILM, G= GOLD(IMMERSION), L=NICKEL, P=8P IRRIDITE, S=SILVER(IMMERSION), T=TIN, N=NONE

PAINT CODES: (SEMI-GLOSS): B=BLUE, G=GREY, H= HAMMERTONE-SILVER, K=BLACK, W=WHITE, Z6=Z306 (BLACK), Z7=Z307(BLACK), N=NONE

TO BUILD A PART NUMBER, USE THE FOLLOWING EXAMPLE:

MODEL 3042-12B-GW Is a Standard 90 Deg. Twist with Cover/Choke Flanges in Copper Alloy Material with Gold Plating and White Paint

PAINT
 PLATING
 ALLOY
 PORT 2 FLANGE
 PORT 1 FLANGE
 WAVEGUIDE SIZE
 COMPONENT TYPE